

WEATHERPROOF HORN LOUDSPEAKERS

➤ APH30T/ENC

EN54-24



TECHNICAL SPECIFICATIONS

EN54-24:2008

Certificate No: 0359-CPD-0166 TYPE B

ELECTRICAL

Rated power, Watts	30
Tappings 100 volt line, Watts	30/15/7.5/3.75
Transformer Impedance, Ohms 100V	330/660/1.32k/2.64k
Tappings 70.7 volt line, Watts	15/7.5/3.75/1.875
Driver impedance, Ohms	8
Effective Frequency Range, Hz (BSEN60268-5)	260-16,000
S.P.L. @ 4m, 1watt, dB, 1/3 Octave, 1KHz	82
S.P.L. @ 1m, 1watt, dB, Test Signal Bandwidth 100Hz-10kHz	108
S.P.L. @ 4m, Full power, dB, 1/3 Octave 1KHz	94
S.P.L. @ 1m, Full power, Test Signal Bandwidth 100Hz-10kHz	122
Dispersion at 1k/2k Hz, Degrees	105/49 Horizontal 142/68 Vertical

ENVIRONMENTAL

IP Rating	66
Max/Min Ambient Temp	70°/-25°C
Relative Humidity	≤95%

MECHANICAL

Dimensions, WxHxD mm	258x180x280
Net Weight, Kgs	2.0
Colour (Unless Specified)	RAL 7035
Material	Low smoke zero Halogen UL-94VD Plastic with UV inhibitors
Mounting	Stainless Steel U bracket and hardware

- APH30T/ENC is supplied with capacitor for DC line monitoring
- APH30T/ENC is BS5839 Part 8 Compliant
- Suitable for external use

Manufacturer reserves the right to alter specifications without notice

September 2016

APH30T/ENC

WEATHERPROOF HORN LOUDSPEAKERS

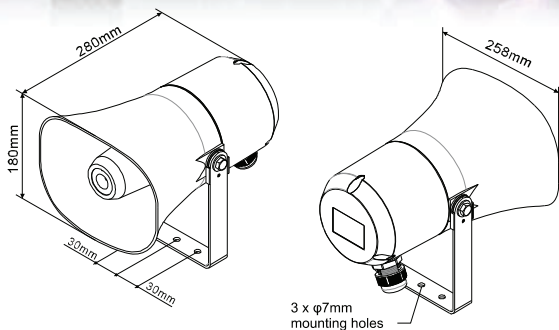

CIRCUIT DIAGRAM

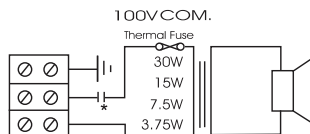

APH30T/ENC
*with capacitor

WITH TRANSFORMER: 100V/70V LINE

	WHITE WIRE PLUS TAPPING				BLACK
100V	3.75W	7.5W	15W	30W	COM
70V	1.875W	3.75W	7.5W	15W	COM
IMP (Ω)	2.64K	1.32K	660	330	

DISPERSION ANGLES

		HORIZONTAL	VERTICAL
1 OCT. PINK NOISE	500 Hz	203°	360°
1 OCT. PINK NOISE	1K Hz	105°	142°
1 OCT. PINK NOISE	2K Hz	49°	68°
1 OCT. PINK NOISE	4K Hz	37°	40°

FREQUENCY RESPONSE

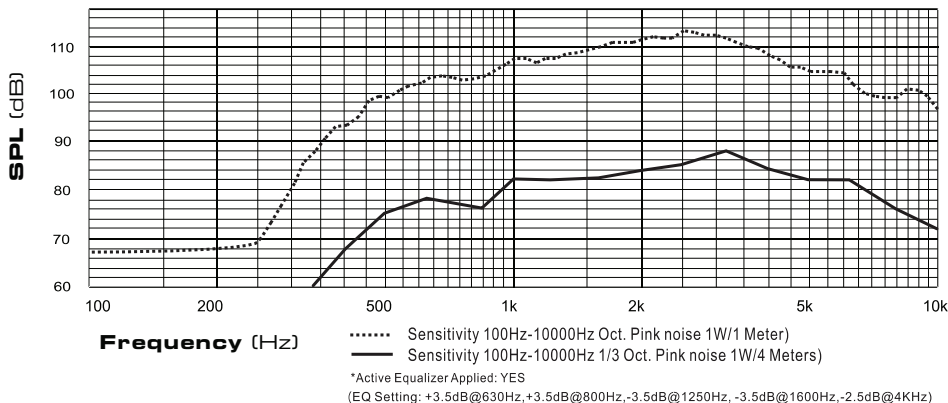

APH30T/ENC has been tested in 100 hours max power (30W). The model does not deviate by more than ± 3dB from the original test value. The frequency response curve and impedance complies with the original one. All SPL tests are performed in an anechoic chamber (<70m³)



Penton UK Ltd

Unit 2 Teville Industrials | Dominion Way | Worthing | West Sussex | BN14 8NW
 T: +44 (0)1903 215315 | F: +44(0)1903 215415 | E: SALES@PENTONUK.CO.UK

www.pentonuk.co.uk

