

USER'S MANUAL  
BEDIENUNGSANLEITUNG  
MANUEL D'UTILISATION  
MANUAL DE USUARIO  
INSTRUKCJA OBSŁUGI  
MANUALE D' USO



# G4 FC

TRACKLIGHT WITH RGBL LED  
CLG4FC / CLG4FCWH

# **CONTENTS / INHALTSVERZEICHNIS / CONTENU / CONTENIDO / TREŚĆ / CONTENUTO**

## **ENGLISH**

INFORMATION ON THIS USER MANUAL	6
INTENDED USE	6
DEFINITIONS AND SYMBOL EXPLANATIONS	6
SAFETY INSTRUCTIONS	7
INSTRUCTIONS FOR INDOOR INSTALLATION EQUIPMENT INCLUDED	11
INTRODUCTION	11
CONNECTIONS, OPERATING AND DISPLAY ELEMENTS	12
OPERATION PER UNIT CONTROLLER CAMEO UNICON (optionally available)	14
MOUNTING	22
FITTING THE DIRECTIONAL GRILLE, DIFFUSER AND FILTER	23
OPTIONAL ACCESSORIES	24
CARE, MAINTENANCE AND REPAIR	24
DIMENSIONS	25
TECHNICAL DATA	26
MINIMUM DISTANCE TO ILLUMINATED SURFACE	27
MINIMUM DISTANCE TO NORMALLY FLAMMABLE MATERIALS	27
DISPOSAL	27
MANUFACTURER'S DECLARATIONS	28

## **DEUTSCH**

INFORMATIONEN ZU DIESER BEDIENUNGSANLEITUNG	29
BESTIMMUNGSGEMÄSSER GEBRAUCH	29
BEGRIFFS- UND SYMBOLERKLÄRUNGEN	29
SICHERHEITSHINWEISE	30
HINWEISE FÜR INDOOR-INSTALLATIONSGERÄTE	34
LIEFERUMFANG	34
EINFÜHRUNG	35
ANSCHLÜSSE, BEDIEN- UND ANZEIGEELEMENTE	36
BEDIENUNG PER UNIT CONTROLLER CAMEO UNICON (optional erhältlich)	38
MONTAGE	46
RICHTGITTER, STREUSCHEIBE UND FILTER MONTIEREN	47
OPTIONALES ZUBEHÖR	48
PFLEGE, WARTUNG UND REPARATUR	49
ABMESSUNGEN	50
TECHNISCHE DATEN	51

MINDESTABSTAND ZUR BELEUCHTETEN FLÄCHE	52
MINDESTABSTAND ZU NORMAL ENTFLAMMBAREN MATERIALIEN	52
ENTSORGUNG	52
HERSTELLERERKLÄRUNGEN	53

## **FRANÇAIS**

INFORMATIONS SUR CE MANUEL D'UTILISATION	54
UTILISATION PRÉVUE	54
DÉFINITIONS ET EXPLICATION DES PICTOGRAMMES	54
CONSIGNES DE SÉCURITÉ	55
INSTRUCTIONS POUR L'INSTALLATION DE L'APPAREIL EN INTÉRIEUR	59
CONTENU DU CARTON	59
INTRODUCTION	60
BRANCHEMENTS, UTILISATION ET INDICATEURS	61
UTILISATION AVEC CONTRÔLEUR CAMEO UNICON (disponible en option)	63
MONTAGE	72
MONTAGE DE LA GRILLE DIRECTIONNELLE, DU DIFFUSEUR ET DU FILTRE	73
ACCESSOIRES EN OPTION	74
ENTRETIEN, MAINTENANCE ET RÉPARATIONS	74
DIMENSIONS	75
CARACÉRISTIQUES TECHNIQUES	76
DISTANCE MINIMALE PAR RAPPORT À LA SURFACE ÉCLAIRÉE	77
DISTANCE MINIMALE PAR RAPPORT AUX MATÉRIAUX NORMALEMENT INFLAMMABLES	77
MISE AU REBUT	78
DÉCLARATIONS DU FABRICANT	78

## **ESPAÑOL**

INFORMACIÓN SOBRE ESTE MANUAL DEL USUARIO	80
USO PREVISTO	80
DEFINICIONES Y EXPLICACIONES DE LOS SÍMBOLOS	80
INSTRUCCIONES DE SEGURIDAD	81
NOTAS PARA LOS EQUIPOS QUE SE INSTALAN EN INTERIORES	85
CONTENIDO DEL EMBALAJE	86
INTRODUCCIÓN	86
CONEXIONES, MANDOS E INDICADORES	87
FUNCIONAMIENTO POR UNIDAD CONTROLADOR CAMEO UNICON (disponible opcionalmente)	89
MONTAJE	97

## **CONTENTS / INHALTSVERZEICHNIS / CONTENU / CONTENIDO / TREŚĆ / CONTENUTO**

MONTAJE DE LA REJILLA DIRECCIONAL, EL DIFUSOR Y EL FILTRO	99
ACCESORIOS OPCIONALES	100
CUIDADO, MANTENIMIENTO Y REPARACIÓN	100
DIMENSIONES	101
DATOS TÉCNICOS	102
DISTANCIA MÍNIMA A LA SUPERFICIE ILUMINADA	103
DISTANCIA MÍNIMA A MATERIALES NORMALMENTE INFLAMABLES	103
RECICLAJE	103
DECLARACIÓN DEL FABRICANTE	104

### **POLSKI**

INFORMACJE NA TEMAT NINIEJSZEJ INSTRUKCJI OBSŁUGI	105
ZAMIERZONE ZASTOSOWANIE	105
DEFINICJE I OBJAŚNIENIA SYMBOLI	105
INSTRUKCJE BEZPIECZEŃSTWA	106
INSTRUKCJE DLA URZĄDZEŃ MONTOWANYCH W POMIESZCZENIACH	110
ZAWARTOŚĆ OPAKOWANIA	110
WPROWADZENIE	111
PRZYŁĄCZA, ELEMENTY OBSŁUGI I WSKAŹNIKI	112
OPERACJA NA JEDNOSTCE STERUJĄCEJ CAMEO UNICON (opcja)	114
MOCOWANIE	122
MONTAŻ KRATKI KIERUNKOWEJ, NAWIEWNIKA I FILTRA	124
AKCESORIA OPCJONALNE	125
PIELĘGNACJA, KONSERWACJA I NAPRAWA	125
WYMIARY	126
DANE TECHNICZNE	127
MINIMALNA ODLEGŁOŚĆ OD OŚWIETLANEJ POWIERZCHNI	128
MINIMALNA ODLEGŁOŚĆ OD MATERIAŁÓW NORMALNIE ŁATWOPALNYCH	128
UTYLIZACJA	128
DEKLARACJE PRODUCENTA	129

### **ITALIANO**

INFORMAZIONI SU QUESTO MANUALE DI ISTRUZIONI	130
USO PREVISTO	130
DEFINIZIONI E SPIEGAZIONI DEI SIMBOLI	130
ISTRUZIONI DI SICUREZZA	131
ISTRUZIONI PER LE APPARECCHIATURE DA INSTALLARE IN INTERNI	135

CONTENUTO DEL L'IMBALLAGGIO	135
INTRODUZIONE	136
CONNESSIONI, ELEMENTI DI COMANDO E DI VISUALIZZAZIONE	137
FUNZIONAMENTO PER UNITÀ CONTROLLER CAMEO UNICON (disponibile come opzione)	139
MONTAGGIO	147
MONTARE LA GRIGLIA DIREZIONALE, IL DIFFUSORE E IL FILTRO	148
ACCESSORI OPZIONALI	149
CURA, MANUTENZIONE E RIPARAZIONE	150
DIMENSIONI (mm)	151
DATI TECNICI	152
DISTANZA MINIMA DALLA SUPERFICIE ILLUMINATA	153
DISTANZA MINIMA DA MATERIALI NORMALMENTE INFLAMMABILI	153
SMALTIMENTO	153
DICHIARAZIONI DEL PRODUTTORE	154
DMX CONTROL / DMX STEUERUNG / PILOTAGE DMX / CONTROL DMX / STEROWANIE DMX / CONTROLLO DMX	155

## ENGLISH

You have made the right choice!

This device has been developed and manufactured to the highest quality standards to ensure many years of problem-free operation. Please read this user manual carefully to be able to use your new Cameo product quickly and optimally. Further information about Cameo Light is available on our website **CAMEOLIGHT.COM**.

### INFORMATION ON THIS USER MANUAL

- Carefully read the safety instructions and the entire manual before operating the device.
- Observe the warnings on the device and in the user manual.
- Always keep the user manual within reach.
- If you sell or pass on the device, it is important that you also include this user manual, as it is an integral part of the product.

### INTENDED USE

This product is a spotlight for permanent installation!

This spotlight is intended exclusively for professional users and is not suitable for private households or third parties!

Use of the product outside the specified technical data and operating conditions, as well as incorrect installation, is considered inappropriate!

Liability for damage and third-party damage to persons and property due to inappropriate use is excluded!

The product is not suitable for:

- Use by persons (including children) with limited physical, sensory or mental abilities or lack of experience and knowledge.
- Children (children must be instructed not to play with the device).

### DEFINITIONS AND SYMBOL EXPLANATIONS

1. **DANGER:** The word DANGER, possibly in combination with a symbol, indicates immediately dangerous situations or conditions for life and limb.
2. **WARNING:** The word WARNING, possibly in combination with a symbol, indicates potentially dangerous situations or conditions for life and limb.
3. **CAUTION:** The word CAUTION, possibly in combination with a symbol, is used to indicate situations or conditions that may lead to injury.
4. **ATTENTION:** The word ATTENTION, possibly in combination with a symbol, refers to situations or states that can lead to damage to property and/or the environment.



This symbol identifies hazards that can cause electric shock.



This symbol identifies hazardous areas or hazardous situations.



This symbol indicates hazards caused by hot surfaces.



This symbol indicates hazards caused by intense light sources.



This symbol indicates a device in which there are no user-replaceable parts.



This symbol indicates additional information on the operation of the product.



This symbol indicates a device that may only be used in dry rooms.

## SAFETY INSTRUCTIONS



### HAZARD:

1. Do not open or modify the unit.
2. If your device no longer functions properly, if liquids or objects get inside it or if it has been damaged in any other way, switch it off immediately and disconnect it from the mains. The device may be repaired only by authorised repair technicians.
3. For devices of protection class 1, the protective conductor must be connected correctly. Never disconnect the protective conductor. Devices of protection class 2 do not have a protective conductor.
4. Ensure that live cables are not kinked or otherwise mechanically damaged.
5. Never bypass the appliance fuse.



### WARNING:

1. The device may not be operated if it shows obvious signs of damage.
2. The device may only be installed in a voltage-free state.
3. If the mains cable of the device is damaged, do not operate the device.
4. Permanently connected power cables may only be replaced by a qualified person.



### ATTENTION:

1. Do not operate the unit if it has been exposed to large temperature fluctuations (for example, after transport). Moisture and condensation can damage the device. Switch on the device only when it has reached room temperature.

2. Make sure that the voltage and frequency of the mains supply correspond to the values indicated on the unit. If the device has a voltage selector switch, do not connect the device until it has been set correctly. Use only suitable power cables.
3. To disconnect the unit from the mains at all poles, it is not sufficient to press the on/off switch on the unit.
4. Make sure that the fuse used corresponds to the type printed on the unit.
5. Make sure that appropriate measures have been taken against overvoltage (e.g. lightning strike).
6. Observe the specified maximum output current on units with Power Out connection. Ensure that the total current consumption of all connected devices does not exceed the specified value.
7. Replace pluggable mains cables only with original cables.

**HAZARD:**

1. Danger of suffocation! Plastic bags and small parts must be kept out of reach of persons (including children) with reduced physical, sensory or mental capabilities.
2. Danger from falling down! Make sure that the device is securely installed and will not fall down. Only use suitable stands or mounts (particularly for fixed installations). Ensure that accessories are properly installed and secured. Ensure that applicable safety regulations are observed.

**WARNING:**

1. Use the device only in the manner intended.
2. Operate the device only with the accessories recommended and intended by the manufacturer.
3. During installation, observe the safety regulations applicable in your country.
4. After connecting the unit, check all cable routes to avoid damage or accidents, e.g. due to tripping hazards.
5. Always observe the specified minimum distance to normally flammable materials! Unless explicitly stated, the minimum distance is 0.3 m.
6. Always observe the minimum distance to the illuminated surface that can be read on the device!

**CAUTION:**

1. In the case of moving components such as mounting brackets or other moving components, there is a possibility of jamming.
2. In the case of units with motor-driven components, there is a risk of injury from the movement of the unit. Sudden movement of the device can cause shock reactions.
3. The housing surface of the device can become very hot during regular operation. Ensure that accidental touching of the housing is not possible. Always allow the lamp to cool sufficiently before removal, maintenance work and charging etc.







### ATTENTION:

1. Do not install or operate the device near any radiators, heat registers, stoves or other heat sources. Ensure that the device is always installed in such a way that it is sufficiently cooled and cannot overheat.
2. Do not place ignition sources such as burning candles near the device.
3. Ventilation openings must not be covered and fans must not be blocked.
4. Use the original packaging or packaging provided by the manufacturer for transport.
5. Avoid shock or impact to the unit.
6. Observe the IP protection class as well as the ambient conditions such as temperature and humidity according to the specification.
7. Devices can be constantly further developed. In the event of deviating information on operating conditions, performance or other device properties between the user manual and the device labelling, the information on the device always takes priority.
8. The unit is not suitable for tropical climates and for operation above 2000 m above sea level.
9. Unless explicitly stated, the unit is not suitable for operation in marine conditions .



For conversion or retrofit sets or accessories provided by the manufacturer, it is essential to observe the instructions included.



### CAUTION! IMPORTANT INFORMATION REGARDING LIGHTING PRODUCTS!

1. Never look directly into the beam of light, not even for a short period of time.
2. Never look into the beam of light using optical devices such as a magnifying glass.
3. Stroboscopic effects may cause epileptic seizures in susceptible individuals!
4. Permanently installed lamps are built into these lighting units. These may not be replaced by the user. The lamps contained in this lighting unit may only be replaced by the manufacturer, its service partner, or a similarly qualified person.



### SIGNAL TRANSMISSION BY RADIO (e.g. W-DMX or audio radio systems):

The quality and performance of wireless signal transmissions generally depends on the ambient conditions. The following factors can impact range and signal stability, for example:

Shielding (e.g. masonry, metal structures, water)

High volume of radio traffic (e.g. powerful wireless LAN networks)

Interference

Electromagnetic radiation (e.g. LED video screens, dimmers)



All range specifications refer to free-field application with visual contact and without interference!

The operation of transmission systems is subject to official regulations. These may vary from region to region and must be checked by the operator before use (e.g. radio frequency and transmission power).



**WARNING:** Devices with wireless signal transmission are not suitable for use in sensitive areas in which radio operation can lead to potential detrimental effects. These include:

- Hospitals, health centres or other healthcare facilities that provide patient treatment with skilled personnel and equipment.
- Hazardous areas Class I, II and III
- Restricted areas
- Military facilities
- Aircraft or vehicles
- Areas where the use of mobile phones is prohibited



#### **TRANSMISSION VIA W-DMX**

**WARNING:** In general, wireless DMX transmission must not be used for applications involving safety-related factors that might result in personal injury or property damage in the event of a failure.

This applies in particular to moving scene or traverse structures, DMX-controlled motors/lifts or lifting devices for operating DMX-operated platform lifts, hydraulic systems or comparable moving components.

Furthermore, wireless DMX transmission must not be used to trigger flame or pyrotechnic devices, explosion-driven effects, or to control gas or liquid effects. These include CO2 cannons, confetti shooters, water effects or similar.



#### **AMBIENT TEMPERATURE**

Please observe the maximum ambient temperature in operation specified in the technical data. A special protection circuit in the headlamp ensures that the brightness is reduced if the ambient temperature is too high to protect the unit components. If you notice a significant loss of brightness in the headlamp, please check the ambient temperature in the direct vicinity of the headlamp and, if necessary, ensure that the temperature is brought to or below the maximum permitted value.



## INSTRUCTIONS FOR INDOOR INSTALLATION EQUIPMENT

1. Equipment for installation applications is designed for continuous operation.
2. Equipment for indoor installation is not weather-resistant.
3. Surfaces and plastic parts can also age in installation equipment, e.g. due to UV irradiation and temperature fluctuations. This generally does not impair functionality.
4. With permanently installed devices, the accumulation of impurities, e.g. dust, is to be expected. Always observe the care instructions.
5. Unless explicitly stated otherwise on the device or in the technical data, the devices are intended for installation heights of less than 5 m.

## INCLUDED

Remove the product from the packaging and remove all packaging material. Please check the completeness and integrity of the delivery and notify your distribution partner immediately after purchase if the delivery is not complete or if it is damaged.

Included in the scope of delivery of the product CLG4FC are:

- ▶ 1 x Cameo G4FC Spotlight, black
- ▶ User manual

The scope of delivery of the product CLG4FCWH includes:

- ▶ 1 x Cameo G4FCWH Spotlight, white
- ▶ User manual

## INTRODUCTION

LED Gallery Light with one 40 W RGBL LED

CLG4FC (black housing)

CLG4FCWH (white housing)

## CONTROL FUNCTIONS

1CH, 2CH 16 bit, 3CH CCT, 3CH Presets, 4CH Direct, 5CH HSI,  
8CH Direct + CCT and 12CH 16 Bit Full Access DMX Control  
W-DMX™

Standalone function (set up via Cameo Unicon)

## FEATURES

Compatible with GLOBAL pro (formerly NOKIA) XTS, XTTS and XTSC 3-phase tracks.  
40 W RGBL LED. W-DMX™. DMX512. RJ45-Anschluss. Operating voltage: 100–240 V AC.  
Diffusing screens, filters and straightening grids optionally available.

The spotlight features the RDM standard (Remote Device Management). This remote device management enables the status query and configuration of RDM end devices via an RDM-capable controller, such as the optionally available Cameo UNICON (item number CLIREMOTE).

The Cameo UNICON also allows access to the entire fixture menu.

## CONNECTIONS, OPERATING AND DISPLAY ELEMENTS

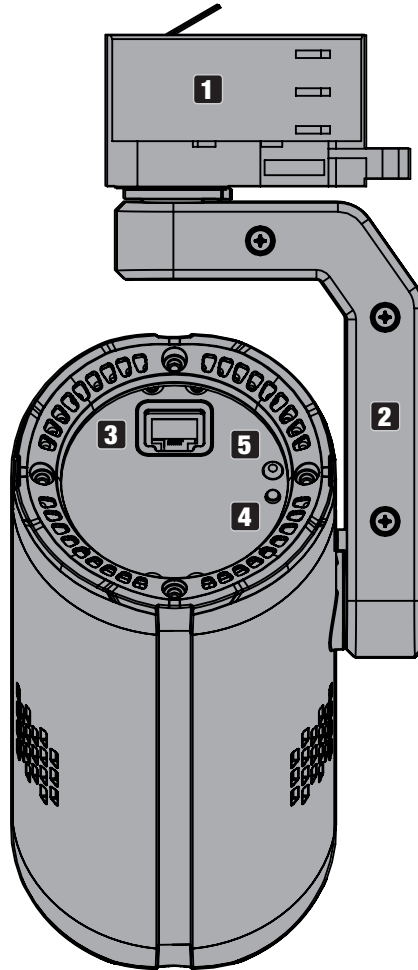

### 1 RAIL ADAPTER

Rail adapter for mounting on a compatible 3-phase rail.

### 2 TILTABLE AND SWIVELLING SUPPORT ARM

Support arm with two joints for adjusting the beam direction on the horizontal and vertical plane.

### 3 RJ45 INTERFACE

Interface for configuring and controlling the fixture using the Cameo UNICON DMX/RDM controller. The fixture can also be configured using another RDM controller and controlled using a standard DMX controller.

Pin assignment:

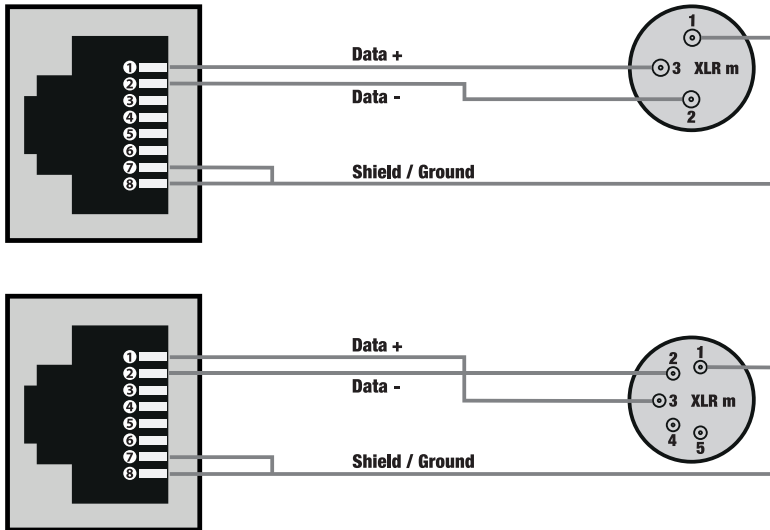

### 4 W-DMX RESET BUTTON

Button for disconnecting W-DMX connections and for pairing the spotlight with W-DMX devices. The housing surface of the device can become very hot during regular operation. Always allow the unit to cool down sufficiently before operating the button. Activate the fixture's W-DMX receiver via Cameo UNICON and reset the receiver by pressing the button for about 3 seconds. All previous connections are disconnected and the receiver is put into pairing standby for about 1 minute, the status LED no. 5 flashes red quickly. The receiver is now waiting for a transmitter pairing request. Start the pairing process on the transmitter; the pairing occurs automatically. In the same way, several receivers can be paired to a transmitter either simultaneously or one after the other. A W-DMX connection is always maintained until the connection is disconnected by means of the Reset command in the receiver or the Unlink command in the transmitter, regardless of whether a device has been disconnected from the power supply in the meantime.

### 5 STATUS LED

The LED shows the current status of the spotlight when controlled via cable and W-DMX.

### Control via cable (RJ45, W-DMX deactivated)

LED lights up permanently blue	DMX signal is present
LED flashes blue	No DMX signal
LED off	Stand-alone operation

### Control via W-DMX™

LED flashes red with approx. 1Hz	Activate W-DMX
LED flashes red quickly	Pairing with a transmitter cancelled and set to pairing readiness
LED is permanently lit green	Paired, DMX signal present
LED flashes green	Paired, no DMX signal

## OPERATION PER UNIT CONTROLLER CAMEO UNICON (optionally available)

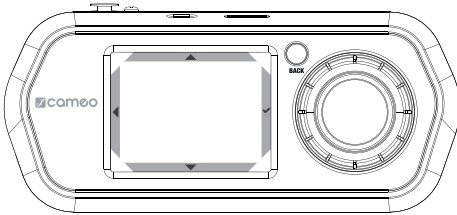

### Functions of the controls

Display		Encoder + BACK
▲	Value up	↻
▼	Value down	↻
◀	Back	Back
✓	Confirm	 Encoder

After you have switched on the Unit Controller UNICON (briefly press BACK to switch on), "Update, Please Wait" (for service purposes only) appears in the display for a short time and then the main menu. Connect the remote unit to the Gallery Light G4 FC via network cable and connect the spotlight to the power supply.

Select the menu item **RDM/Fixture** and confirm the selection. Now the system searches for connected RDM devices (Discovery) and if the G4 FC is correctly connected and switched on, a device is found (Discovered: 1). After a short time, the G4 FC is displayed as the only unit in a list (the first part of the displayed RDM unit shows the unit model, the second part behind "/" is the label and can be individually adjusted in the menu item **Label** for easier identification). Now confirm to enter the submenu.

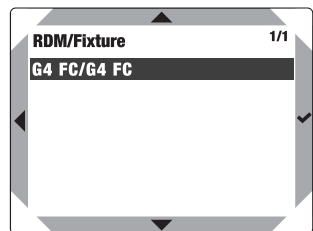
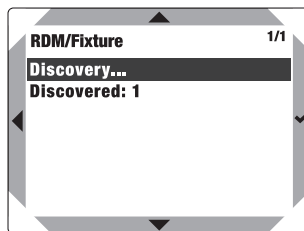
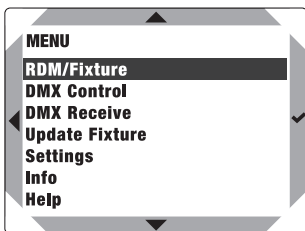

All information and configuration options for the spotlight that can be called up and edited via RDM are now displayed.

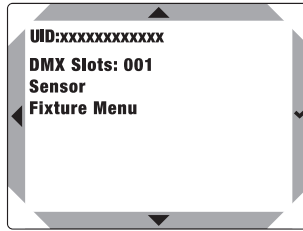
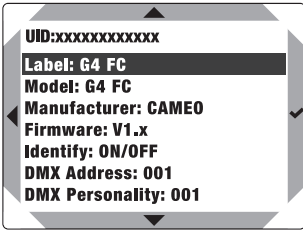



List of information and configuration options with explanations:

<b>UID:</b>	Individual and unchangeable identification number of the selected RDM device	
<b>Label:</b>	Individually adjustable marking of the RDM unit	
<b>Model:</b>	Device model	
<b>Manufacturer:</b>	Device manufacturer	
<b>Firmware:</b>	Device firmware	
<b>Identify:</b>	<b>ON</b>	Selected spotlight flashes with approx. 1 Hz
	<b>OFF</b>	Flashing disabled
<b>DMX address</b>	Current DMX start address (can be edited in the menu option)	
<b>DMX Personality:</b>	Current DMX mode (can be edited in the menu option)	
<b>DMX slots:</b>	Number of channels in current DMX mode	
<b>Sensor</b>	LED temperature (press  to display)	
<b>Fixture Menu</b>	Individual Cameo device menu for editing settings (see <b>DEVICE MENU (Fixture Menu)</b> )	

## LABEL

In the RDM/Fixture menu, select **Label** and confirm the selection to individually name the RDM device.



Select characters:	 or  or turn the encoder
Delete all characters:	<b>Reset</b>
Set space:	<b>Space</b>
Reset position:	<b>Clean</b>
Secure labelling:	<b>Save</b>
Confirm command or character and select the next digit:	Press  or encoder

## DEVICE MENU (Fixture Menu):

In the RDM/Fixture menu, select **Fixture Menu** and confirm the selection.

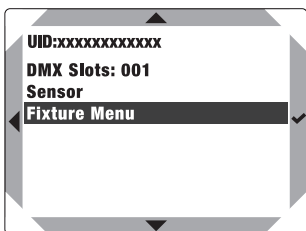

## CONFIGURE DMX START ADDRESS

Select **DMX Address**, confirm the selection, set the desired DMX address and confirm the entry. (highest value depends on the currently activated DMX operating mode)

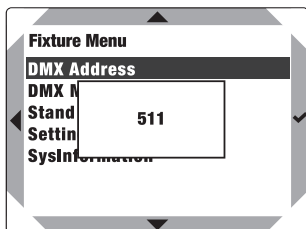
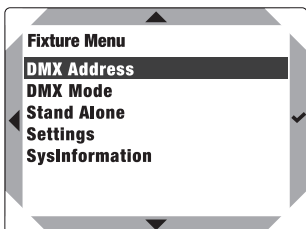

## SELECT DMX MODE

Select **DMX Mode**, confirm the selection, then select the desired DMX mode and confirm the selection.

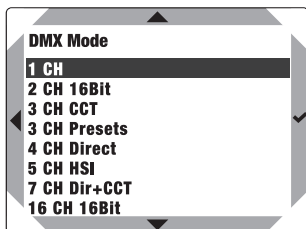
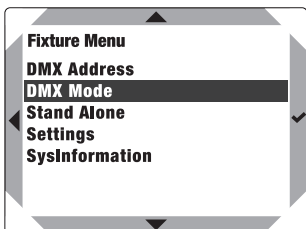

## AUTO STANDALONE MODE

The 6 available auto-programs each comprise non-editable colour-change sequences. Brightness (Dimmer) and running speed (Speed) are separately adjustable in each programme.

Select **Stand Alone**, confirm the selection, then select **Auto** and confirm again. Now select the desired program (Program 1 - Program 6) and confirm again. Now select **Dimmer** or **Speed**, confirm and set the brightness or speed value from 001 to 100 as desired. Confirm all entries.



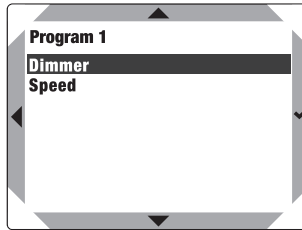
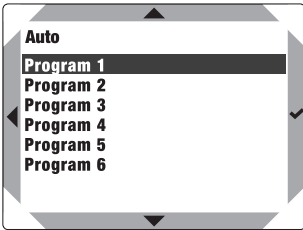
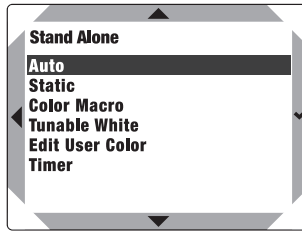
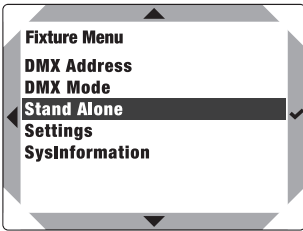

## STATIC STANDALONE MODE

The Static standalone mode allows the Dimmer, Dimmer Fine, Strobe and RGBAL values to be set directly on the device with values between 000 and 255, in a similar way to with a DMX controller. In this way, an individual scene can be created without an additional DMX controller.

Select **Stand Alone**, confirm the selection, then select **Static** and confirm again. Now select the menu item you wish to edit and confirm the selection. In the selected menu item, set the desired value from 000 to 255 and confirm the entry. The values for the strobe effect correspond to the values in channel 2 of the DMX table 3 CH presets.

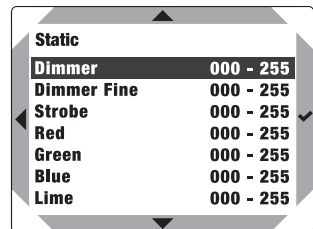
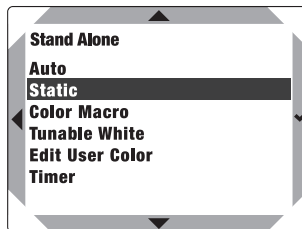
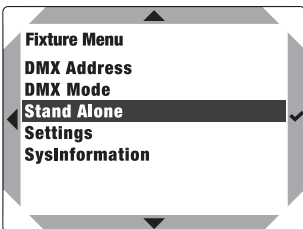

## STANDALONE MODE COLOR MACRO

15 different colour macros and 4 individual colours (User Color 1-4) are available as presets. The brightness can be adjusted for each preset.

Select **Stand Alone**, confirm the selection, then select **Color Macro** and confirm again. Select the desired colour preset and confirm (Color Off = blackout). The brightness of the selected preset can now be adjusted from 000 to 100. Confirm all entries.

The individual colours User Color 1-4 are created in menu item **Edit User Color** in the **Stand Alone** menu.

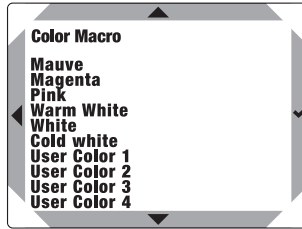
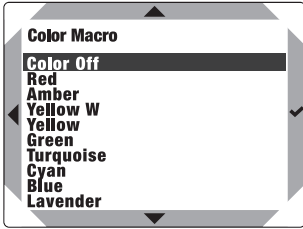
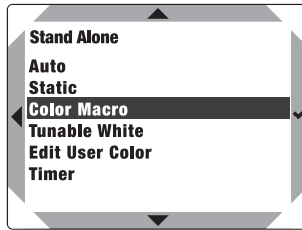
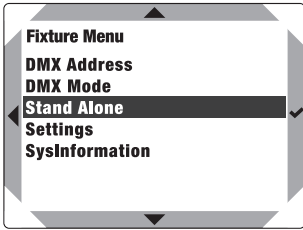

## STANDALONE MODE TUNEABLE WHITE

In the standalone mode Tuneable White, the colour temperature (CCT) can be adjusted from 1800 K to 6500 K in 100 K increments, in addition to the brightness (Dimmer) and colour (Tint).

Select **Stand Alone**, confirm the selection, then select **Tunable White** and confirm again. Now select the menu item you wish to edit and confirm the selection. Set the desired value and confirm the entry.

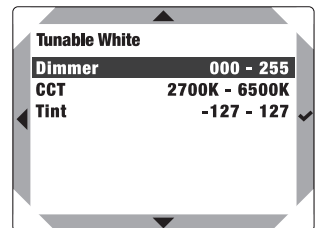
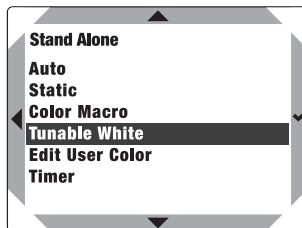
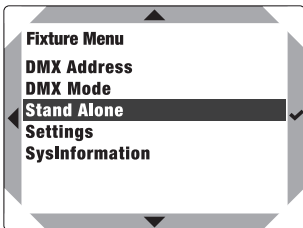

## STAND-ALONE CATEGORY EDIT USER COLOUR

In the stand-alone category Edit User Color, you have the option of saving brightness (Dimmer and Dimmer Fine), stroboscope (Strobe) and a colour mix of R, G, B and L directly in the unit in four individual colour presets.

Select **Stand Alone**, confirm the selection, then select **Edit User Color** and confirm again. Select the desired preset (Color 1 - Color 4) and confirm the selection. Now select the menu item you wish to edit and confirm. Set the desired value from 000 to 255 and confirm again. The values for the strobe effect correspond to the values in channel 2 of the DMX table 3 CH presets.

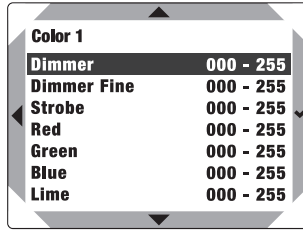
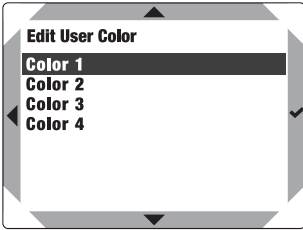
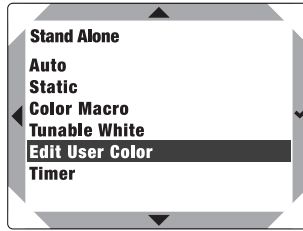
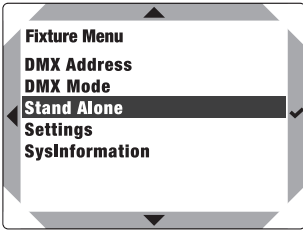

## TIMER FUNCTION

The timer function allows the standalone modes Static, Color Macro and Tuneable White to be timer controlled in such a way that the Fade In time can be configured from 0.5 seconds to 24 hours, the Dwell Time from 0.5 seconds to 24 hours and infinite (Limitless) and the Fade Out time from 0.5 seconds to 24 hours. After activation of the timer function, the timer control will be implemented upon the next system start.

Select **Stand Alone**, confirm the selection, then select **Timer** and confirm again. Under **Switch**, select the setting **On** and confirm. For the individual timer control settings, select **Fade In**, **Dwell Time** or **Fade Out** and confirm. You can now set the respective value as desired. Confirm all entries. To deactivate the timer function, under point **Switch**, select the setting **Off** and confirm.

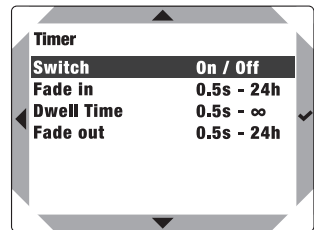
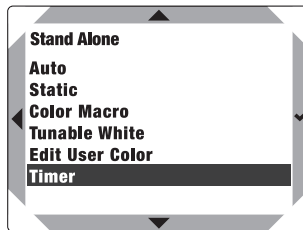
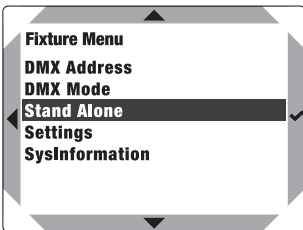

## SYSTEM SETTINGS (Settings)

Select **Settings** and confirm.

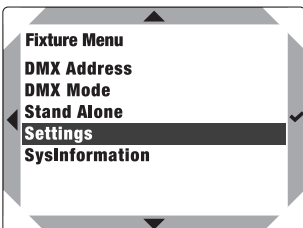

This will take you to the submenu for configuring the submenu items (see table):

<b>Settings</b>				
DMX Fail	=	Operational status with DMX signal fault	Hold	Last command is retained
			User Colour 1	Activates User Color 1
			Fade out 10s	10 seconds fade to blackout
			Blackout	Activates blackout
			Full On	All LEDs 100% output
Dimmer Curve	=	Dimmer curve	Linear	Light intensity increases linearly with DMX value
			Exponential	Light intensity can be finely adjusted at lower DMX values and broadly adjusted at higher DMX values
			Logarithmic	Light intensity can be broadly adjusted at lower DMX values and finely adjusted at higher DMX values
			S-curve	Light intensity can be finely adjusted at lower and higher DMX values and broadly adjusted at medium DMX values
Dimmer Response	=	Dimmer response	LED	Light responds abruptly to changes in DMX value
			Halogen	Light behaves like a halogen spotlight with slight brightness changes
Red Shift	=	Accurately mimics the colour drift of dimming a halogen spotlight.	Off	Colour drift is disabled
		Spotlight, the colour temperature automatically changes progressively to warm white and amber (and vice versa).	On	Colour drift is enabled
PWM Frequency	=	Configuration of PWM frequency	800 Hz / 1200 Hz / 2000 Hz / 3600 Hz / 12 kHz / 25 kHz	
Calibration	=	Colour calibration	Red	Individual colour calibration. Cross-mode brightness setting of R, G, B, A and L with values from 000 - 255.
			Green	
			Blue	
			Lime	
W-DMX	=	Switching wireless control on and off	Off	Wireless control disabled
			On	Wireless control activated

Status LED	=	Set status LED	Always On	LED Permanently on
			OFF	LED off
			Off after 30s	LED is switched off after 30 seconds
Power	=	Operating mode	Constant	Constant brightness over long periods
			Maximum	Maximum brightness
Factory Reset	=	Reset to factory settings	Reset?	Resetting to factory settings: Perform reset with ENTER, cancel with MENU
Factory Reset WC	=	Reset to factory settings except User Colors	WC Reset?	Resetting to factory settings apart from User Colors: Perform reset with ENTER, cancel with MENU

### SYSTEM INFORMATION (SysInformation)

Starting from the main display, press the encoder to enter the main menu . Select the menu item **SysInformation** and confirm the selection.

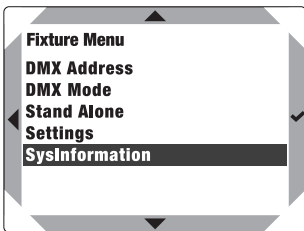

This will take you to the submenu for accessing the system information (see table):

SysInformation				
Firmware	=	Displays device firmware	Main CPU V1.xx	
Temperature	=	Displays temperature of LED unit	LED TEMP	xx °C / xx °F
			Temperature Unit	Celsius (= display in degrees Celsius) Fahrenheit (= display in degrees Fahrenheit)
Operation Hours	=	Displays operating time	xx:xx h	Display of the unit operating time in hours and minutes

## MOUNTING



**HAZARD:** Overhead mounting requires extensive experience, including the calculation of the load limit values of the installation material and regular safety inspection of all installation materials and spotlights. If you do not have these qualifications, do not attempt to perform an installation yourself. Refer instead to a qualified professional. There is a risk that devices that are incorrectly mounted and secured may come loose and fall down. This can cause serious injury or death.



**DANGER:** Only use the spotlight for horizontally mounted rails (horizontal ceiling mounting)! The spotlight is not suitable for inclined rails and wall mounting!



**WARNING:** Before mounting or dismantling, make sure that no electrical voltage is applied to the 3-phase rail (switch off fuses)!



**ATTENTION:** The spotlight is not suitable for use with external dimmers!

Use the knurled wheel A to set to phase 1, 2 or 3 (see window below the knurled wheel; 0 = off). The adjustment can be made before or after mounting on a rail.

To mount on a rail, open the locking lever B of the rail adapter (lever in open position in the illustration) and then press the adapter into the rail until it lies flat on the rail edges (Fig. 1).

Secure the connection by closing the locking lever again (Fig. 2).

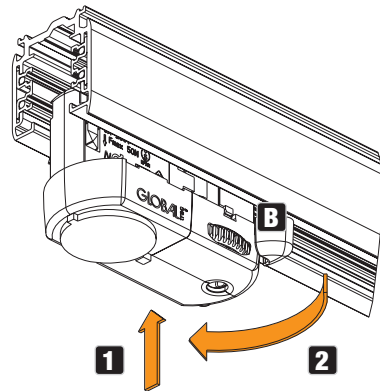
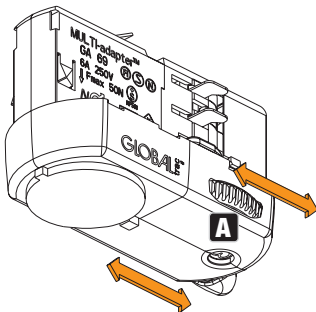

To dismantle the headlamp, open the locking lever (fig. 3) and pull the headlamp downwards out of the rail (fig. 4).

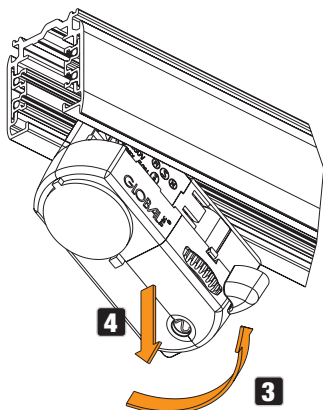

## FITTING THE DIRECTIONAL GRILLE, DIFFUSER AND FILTER

Up to three optionally available accessories can be mounted in combination in front of the headlamp's exit lens (see OPTIONAL ACCESSORIES).

Remove the end ring held by strong magnets from the headlamp (fig. A) and then remove the retaining ring, also held by magnets, from the end ring (fig. B). Now place the desired accessories (in example C, first the straightening grid, then a diffusing disc and then a CTO filter) in the end ring and then place the retaining ring on the accessories in the end ring. Which of the three possible positions the retaining ring is placed in depends on the total height of the inserted accessories.

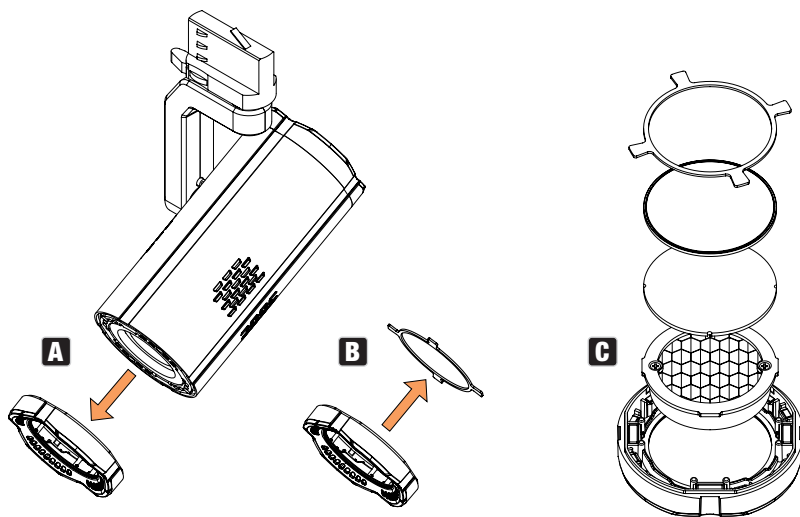

Now place the end ring including accessories on the lamp as shown in figure D.

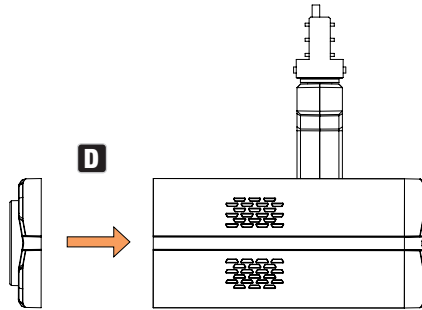

## OPTIONAL ACCESSORIES

### Filter

CLG4CTB (CTB Filter)  
CLG4CTO (CTO filter)

### Diffusers

CLG46010LENS (60° x 10°)  
CLG410LENS (10°)  
CLG420LENS (20°)  
CLG430LENS (30°)  
CLG460LENS (60°)

### Straightening grids

CLG4HC (Honeycomb, black)  
CLG4HCWH (Honeycomb, white)

## CARE, MAINTENANCE AND REPAIR

In order to ensure the long-term, proper functioning of the device, it must be regularly cleaned and, if necessary, maintained. The maintenance requirement depends on the intensity of use and the environment in which it is used.

We generally recommend a visual inspection before each operation. Furthermore, we recommend carrying out all the applicable maintenance measures specified below once every 500 operating hours or, in the case of a lower intensity of use, at the latest after one year. Warranty claims may be limited in the event of defects resulting from inadequate maintenance.

### CARE (carried out by user)



**WARNING!** Before carrying out any care or maintenance, the power supply – and, if possible, all device connections – must be disconnected.



**PLEASE NOTE!** Improper care can lead to impairment of the device or even its destruction.



1. Housing surfaces must be cleaned with a clean, damp cloth. Make sure that no moisture can penetrate the device.
2. Air inlets and outlets must be regularly cleaned of dust and dirt. If compressed air is used, make sure that damage to the device is prevented (e.g. fans must be blocked in this case).
3. Lines and plug contacts must be cleaned regularly and dust and dirt must be removed.
4. In general, no cleaning agents or abrasive agents may be used, otherwise the surface finish may be damaged.
5. Devices must generally be stored dry and protected from dust and dirt.

### MAINTENANCE AND REPAIR (by qualified personnel only)



**HAZARD!** There are live components in the device. Even after disconnecting the mains connection, there may still be residual voltage in the device, for example, due to charged capacitors.



**PLEASE NOTE!** There are no user-serviceable assemblies in the device.



**PLEASE NOTE!** Maintenance and repair work may only be carried out by qualified specialist personnel authorised by the manufacturer. If in doubt, consult the manufacturer.



**PLEASE NOTE!** Improperly performed maintenance work may affect the warranty claim.

### DIMENSIONS (mm)

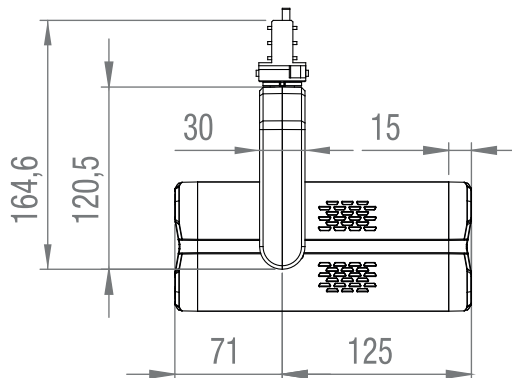

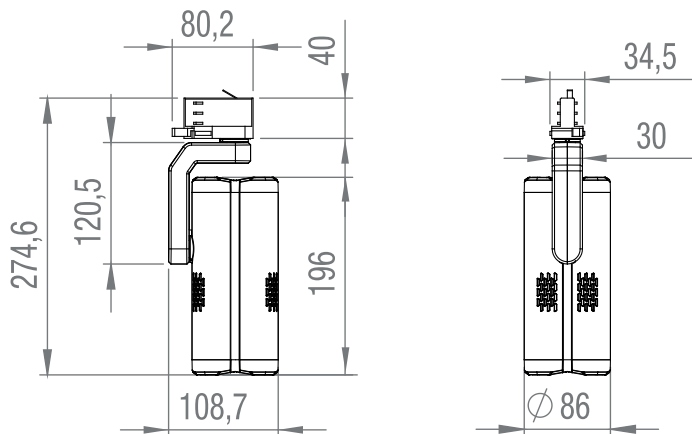

## TECHNICAL DATA

<b>Product number:</b>	<b>CLG4FC(WH)</b>
Product type:	LED spotlight
Type:	Installation spotlight
Colour spectrum:	RGBL
Number of LEDs:	1
LED type:	4in1 Chip
LED output:	40 W
LED PWM frequency:	800 Hz, 1200 Hz, 2000 Hz, 3600 Hz, 12 kHz, 25 kHz(adjustable)
Half chaff angle:	5
Tenth scattering angle:	10
DMX input:	1x RJ45
DMX output:	----
DMX functions:	Dimmer, Dimmer Fine, Strobe, Red, Green, Blue, Lime, Hue, Saturation, Colour Temperature, Tint, Colour Presets, Colour Blending, Record User Colours, Device Settings
Control:	DMX512, W-DMX™, RDM
Standalone functions:	Static
Operating controls:	W-DMX Button + External Control Remote
Operating voltage:	100–240 V AC/50–60 Hz
Power consumption:	40 W
Inrush current:	45A / 0.3ms (first half-wave)
Luminous flux:	FULL ON: 410lm

Colour reproduction index Ra	>77 @6500K
Compatible rails:	GLOBAL pro (formerly NOKIA) XTS, XTTS and XTSC 3-phase tracks
Power supply connection:	Rail adapter (selectable phase)
Ambient temperature (in operation):	0°C – 40°C
Relative air humidity:	<80%, non-condensing
Housing colour:	Black (CLG4FC) White (CLG4FCWH)
Housing material:	Metal
Housing cooling:	Convection cooling
Minimum distance to illuminated surface:	0.5 m
Minimum distance to normally flammable materials:	0.5 m
Dimensions (Ø x L, without support arm):	86 x 196 mm
Weight:	1.3 kg
RDP (Material Group A)	0,25 @ 2700K; 0,44 @ 6500K
RDP (Material Group B)	0,58 @ 2700K; 0,60 @ 6500K
Accessories (optional):	Interchangeable lenses (10°, 20°, 30°, 60°, 60°x10°) Honeycomb, CTO filter, CTB filter

## MINIMUM DISTANCE TO ILLUMINATED SURFACE

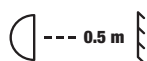

This symbol with distance specification in metres (m) indicates the minimum distance between the light head and the illuminated surface. In this example, the distance is 0.5 m. Please refer to the technical data in this manual and the imprint on the unit casing for the value valid for this unit!

## MINIMUM DISTANCE TO NORMALLY FLAMMABLE MATERIALS



This symbol with distance specification in metres (m) indicates the minimum distance between the light head and normally flammable materials. In this example, the distance is 0.5 m. Please refer to the technical data in this manual for the value valid for this unit!

## DISPOSAL



### PACKAGING:

1. Packaging can be fed into the reusable material cycle using the usual disposal methods.
2. Please separate the packaging in accordance with the disposal laws and recycling regulations in your country.



### DEVICE:

1. This appliance is subject to the European Directive on Waste Electrical and Electronic Equipment as amended. WEEE Directive Waste Electrical and Electronic Equipment. Old appliances do not belong in household waste. The old device must be disposed of via an approved disposal company or a municipal disposal facility. Please observe the applicable regulations in your country!
2. Observe all disposal laws and regulations applicable in your country.
3. As a private customer, you can obtain information on environmentally-friendly disposal options from the seller of the product or the appropriate regional authorities.

## MANUFACTURER'S DECLARATIONS

### Manufacturer's warranty & limitation of liability

Adam Hall GmbH, Adam-Hall-Str. 1, D-61267 Neu-Anspach /

E-Mail [Info@adamhall.com](mailto:Info@adamhall.com) / +49 (0)6081 / 9419-0

Our current warranty conditions and limitation of liability can be found at:

[https://cdn-shop.adamhall.com/media/pdf/Manufacturers-Declarations-CAMEO\\_DE\\_EN\\_ES\\_FR.pdf](https://cdn-shop.adamhall.com/media/pdf/Manufacturers-Declarations-CAMEO_DE_EN_ES_FR.pdf)

In case of service, please contact your sales partner.

### CE conformity

Adam Hall GmbH hereby confirm that this product meets the following guidelines (where applicable):

Low-Voltage Directive (2014/35/EU)

EMC Directive (2014/30/EU)

RoHS (2011/65/EU)

RED (2014/53/EU)

### EC Declaration of Conformity

Declarations of conformity for products subject to the LVD, EMC, RoHS Directive can be requested from [info@adamhall.com](mailto:info@adamhall.com)

Declarations of conformity for products subject to RED can be downloaded from [www.adamhall.com/compliance/](http://www.adamhall.com/compliance/)

**Subject to misprints and errors, as well as technical or other modifications!**

# DMX CONTROL / DMX STEUERUNG / PILOTAGE DMX / CONTROL DMX / STEROWANIE DMX / CONTROLLO DMX

1CH (user color 1)	2CH 16 Bit (user color 1)	Function	Values			
1	1	Dimmer	000	-	255	0% to 100%
	2	Dimmer fine	000	-	255	0% to 100%

3CH Presets	5CH HSI	Function	Values				Sub- Group
1	1	Dimmer	000	-	255	0% to 100%	Dimmer
2		Strobe functions	000	-	005	Strobe open	Multi- functional Strobe
			006	-	010	Strobe closed	
			011	-	022	Ramp up/down, slow -> fast	
			023	-	033	Ramp up/down random, slow->fast	
			034	-	045	Ramp up, slow -> fast	
			046	-	056	Ramp up random, slow -> fast	
			057	-	068	Ramp down, slow -> fast	
			069	-	079	Ramp down random, slow -> fast	
			080	-	102	Random Strobe effect, slow -> fast	
			103	-	127	Strobe Break effect, 5s.....1s (Short burst with break)	
			128	-	250	Strobe slow -> fast <1Hz - 20Hz	
			251	-	255	Strobe open	
	2	Hue	000	-	255	0° (RED) thru 360°	HSI
	3	Saturation	000	-	255	From 0% (white) to 100% pure color	
	4	Color Temperature (affects RGBL or HSI)	000	-	005	No function	CCT
			006	-	006	Warm white	
			007	-	046	Warm white -> 2700K	
			047	-	047	Bulb White (2700K)	
			048	-	087	2700K -> 3200K	
			088	-	088	Halogen White (3200K)	
			089	-	128	3200K -> 4000K	
			129	-	129	Neutral White (4000K)	

4	Color Temperature (affects RGBL or HSI)	130 - 169	4000K -> 5600K	CCT
		170 - 170	Studio-White (5600K)	
		171 - 210	5600K -> 6500K	
		211 - 211	Daylight White (6500K)	
		212 - 251	6500K -> cold Daylight	
		252 - 255	Cold Daylight	
5	Tint (affects Color Temperature)	000 - 000	Off	Tint
		001 - 127	Magenta -> Neutral	
		128 - 128	neutral	
		129 - 255	Neutral -> Green	
3	Color Presets (override HSI, Color Temperature)	000 - 005	Color off	Color Presets
		006 - 013	Red	
		014 - 021	Amber	
		022 - 029	Yellow warm	
		030 - 037	Yellow	
		038 - 045	Green	
		046 - 053	Turquoise	
		054 - 061	Cyan	
		062 - 069	Blue	
		070 - 077	Lavender	
		078 - 085	Mauve	
		086 - 093	Magenta	
		094 - 101	Pink	
		102 - 109	Warm White	
		110 - 117	White	
		118 - 125	Cold White	
		126 - 127	Color Jumping Stop	
		128 - 164	Color Jumping Speed slow->fast / Color 1 -> 12	
		165 - 201	Color Fading Speed slow -> fast / Color 1 -> 12	
		202 - 207	User Color_1	
208 - 213	User Color_2			
214 - 219	User Color_3			
220 - 225	User Color_4			
226 - 255	no function			

3CH CCT	Function	Values			
1	Dimmer	000	-	255	0% to 100%
2	Color Temperature	000	-	006	Warm white

2	Color Temperature	007 - 046	Warm white -> 2700K
		047 - 047	Bulb White (2700K)
		048 - 087	2700K -> 3200K
		088 - 088	Halogen White (3200K)
		089 - 128	3200K -> 4000K
		129 - 129	Neutral White (4000K)
		130 - 169	4000K -> 5600K
		170 - 170	Studio-White (5600K)
		171 - 210	5600K -> 6500K
		211 - 211	Daylight White (6500K)
		212 - 251	6500K -> cold Daylight
3	Tint (affects Color Temperature)	000 - 000	Off
		001 - 127	Magenta -> Neutral
		128 - 128	Neutral
		129 - 255	Neutral -> Green

4CH Direct	Function	Values		
1	Red	000 - 255	0% to 100%	
2	Green	000 - 255	0% to 100%	
3	Blue	000 - 255	0% to 100%	
4	Lime	000 - 255	0% to 100%	

8CH Direct CCT	12CH Full Access	Function	Values			Sub-Group
1	1	Dimmer	000 - 255	0% to 100%		Dimmer
	2	Dimmer fine	000 - 255	0% to 100%		
	3	Strobe functions	000 - 005	Strobe open		Multifunctional Strobe
			006 - 010	Strobe closed		
			011 - 022	Ramp up/down, slow -> fast		
			023 - 033	Ramp up/down random, slow->fast		
			034 - 045	Ramp up, slow -> fast		
			046 - 056	Ramp up random, slow -> fast		
	057 - 068	Ramp down, slow -> fast				

ENGLISH	3	Strobe functions	069 - 079	Ramp down random, slow -> fast	Multifunctional Strobe
			080 - 102	Random Strobe effect, slow -> fast	
			103 - 127	Strobe Break effect, 5s....1s (Short burst with break)	
			128 - 250	Strobe slow -> fast <1Hz - 20Hz	
			251 - 255	Strobe open	
2	4	Red	000 - 255	0% to 100%	Color Mixing
3	5	Green	000 - 255	0% to 100%	
4	6	Blue	000 - 255	0% to 100%	
5	7	Lime	000 - 255	0% to 100%	
FRANCAIS	6	Color Temperature (affect RGBL or HSI)	000 - 005	No function	CCT
			006 - 006	Warm white	
			007 - 046	Warm white -> 2700K	
			047 - 047	Bulb White (2700K)	
			048 - 087	2700K -> 3200K	
			088 - 088	Halogen White (3200K)	
			089 - 128	3200K -> 4000K	
			129 - 129	Neutral White (4000K)	
			130 - 169	4000K -> 5600K	
			170 - 170	Studio-White (5600K)	
			171 - 210	5600K -> 6500K	
			211 - 211	Daylight White (6500K)	
			212 - 251	6500K -> cold Daylight	
252 - 255	Cold Daylight				
ESPAÑOL	7	Tint (affects Color Temperature)	000 - 000	Off	Tint
			001 - 127	Magenta -> Neutral	
			128 - 128	neutral	
			129 - 255	Neutral -> Green	
POLSKI	10	Color Presets (override RGB, HSI, Color Temperature)	000 - 005	Color off	Color Presets
			006 - 013	Red	
			014 - 021	Amber	
			022 - 029	Yellow warm	
			030 - 037	Yellow	
			038 - 045	Green	
			046 - 053	Turquoise	
			054 - 061	Cyan	
			062 - 069	Blue	
ITALIANO	DMX				



	10	Color Presets (override RGB, HSI, Color Temperature)	070 - 077	Lavender	Color Presets
			078 - 085	Mauve	
086 - 093			Magenta		
094 - 101			Pink		
102 - 109			Warm White		
110 - 117			White		
118 - 125			Cold White		
126 - 127			Color Jumping Stop		
128 - 164			Color Jumping Speed slow->fast / Color 1 -> 12		
165 - 201			Color Fading Speed slow-> fast / Color 1 -> 12		
202 - 207			User Color_1		
208 - 213			User Color_2		
214 - 219			User Color_3		
220 - 225			User Color_4		
226 - 255	no function				
11	Color Preset Crossfade (Affects Color Temperature, HSI too)	000 - 005	no function	Device settings	
		006 - 105	0,1s - 10s (0,1s Steps)		
		106 - 214	11s - 119s (1s Steps)		
		215 - 244	2m - 4m50s (10s Steps)		
		245 - 255	5m - 15m (1m Steps)		
8	12	Device settings (please read remark 1*)	000 - 024	No function	Device settings
			025 - 025	Record User Color 1 (hold 3s)	
			026 - 026	Record User Color 2 (hold 3s)	
			027 - 027	Record User Color 3 (hold 3s)	
			028 - 028	Record User Color 4 (hold 3s)	
			029 - 073	No function	
			074 - 075	Dimmer Response LED (hold 3s)	
			076 - 077	Dimmer Response Halogen (hold 3s)	
			078 - 085	No function	
			086 - 087	No function	
			088 - 089	No function	

8	12	Device settings (please read remark 1*)	090 - 119	no function	Device settings
			120 - 121	PWM 1 (800 Hz) (hold 3s)	
			122 - 123	PWM 2 (1200 Hz)(hold 3s)	
			124 - 125	PWM 3 (2000 Hz)(hold 3s)	
			126 - 127	PWM 4 (3600 Hz)(hold 3s)	
			128 - 129	PWM 5 (12 KHz)(hold 3s)	
			130 - 131	PWM 6 (25 KHz)(hold 3s)	
			132 - 163	No function	
			164 - 165	Dimmer Curve Linear (hold 3s)	
			166 - 167	Dimmer Curve Exponential (hold 3s)	
			168 - 169	Dimmer Curve Logarithmic (hold 3s)	
			170 - 171	Dimmer Curve S-Curve (hold 3s)	
			172 - 235	No function	
			236 - 237	Reset All Functions (except DMX-Address and Mode) (hold 3s)	
			238 - 239	Reset All Function (except User Colour, DMX-Address and Mode) (hold 3s)	
240 - 255	No function				

**EN:** (1\*) After the adjustments have been made, set the value to 000 to avoid disturbance by endless function call.

**DE:** (1\*) Nachdem die Einstellungen vorgenommen wurden, stellen Sie den Wert auf 000 ein, um Störungen durch endlosen Funktionsaufruf zu vermeiden.

**FR:** (1\*) Une fois les ajustements effectués, réglez la valeur sur 000 pour éviter les perturbations par appel de fonction sans fin.

**ES:** (1\*) Después de realizar los ajustes, establezca el valor en 000 para evitar perturbaciones mediante una llamada de función sin fin.

**PL:** (1\*) Po dokonaniu ustawień ustaw wartość na 000, aby uniknąć zakłóceń przez niekończące się wywołanie funkcji.

**IT:** (1\*) Dopo aver effettuato le regolazioni, impostare il valore su 000 per evitare disturbi causati da una chiamata a funzione infinita.

DMX

ITALIANO

POLSKI

ESPAÑOL

FRANCAIS

DEUTSCH

ENGLISH

ENGLISH

DEUTSCH

FRANCAIS

ESPAÑOL

POLSKI

ITALIANO

DMX

DMX

ITALIANO

POLSKI

ESPAÑOL

FRANCAIS

DEUTSCH

ENGLISH



**CAMEOLIGHT.COM**

**Adam Hall GmbH**

Adam-Hall-Str. 1 | 61267 Neu-Anspach | Germany

Phone: +49 6081 9419-0 | [adamhall.com](http://adamhall.com)

Adam Hall Ltd. | The Seedbed Business Centre | SS3 9QY Essex | United Kingdom



REV: 03