

INSTRUCTION MANUAL

XMR520PL

SPLASH WATERPROOF WIDE RANGE MUSIC HORN WITH LINE MATCHING TRANSFORMER

WARNING

1. Speakers must be wired in parallel and connected to the correct line terminals of amplifier.
2. Ensure that all speakers have the same polarity with respect to each other.
3. The sum of all the tapings must not exceed 80% of the amplifier's rated output.
4. Do not use this speaker with its front upward to prevent malfunction.
5. This speaker is not suitable for mounting on a car.

SPECIFICATION

Model No.	XMR520PL
Rated Power (rms)	20W
Impedance	250Ω, 500Ω, 1 kΩ, 2 kΩ, 4 kΩ & 8Ω
Power Taps @ 100V	20W, 10W, 5W, 2.5W & 8Ω
Power Taps @ 70V	20W, 10W, 5W, 2.5W, 1.25W & 8Ω
SPL (1W/1M)	98dB
Max. SPL (20W/1M)	111dB
Frequency Range (-10dB)	130 Hz ~ 20K Hz
Dispersion 1K Hz/4K Hz	130° / 30°
Water Protection	IEC529 IP 55
Power Selection Way	7-core cable
Material	High impact ABS with UV resistance
Color/Finish	Ivory (RAL 1013)
Dimensions	184 (7.24) Dia. x 200 (7.87) L mm. (in.)
Net Weight	2.2 Kgs (4.85 lbs.)
Mounting	U Type Steel Bracket

Frequency Response

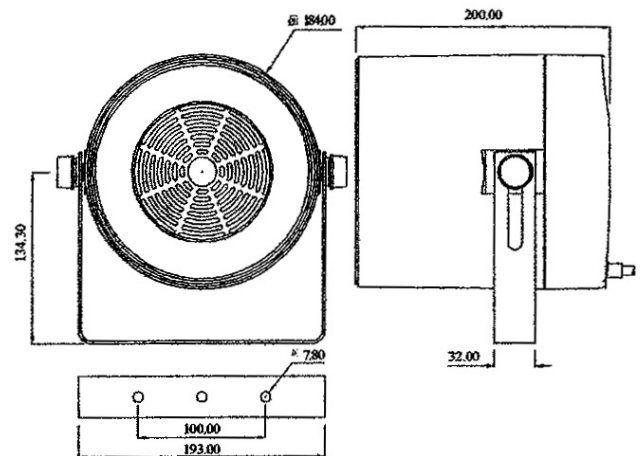
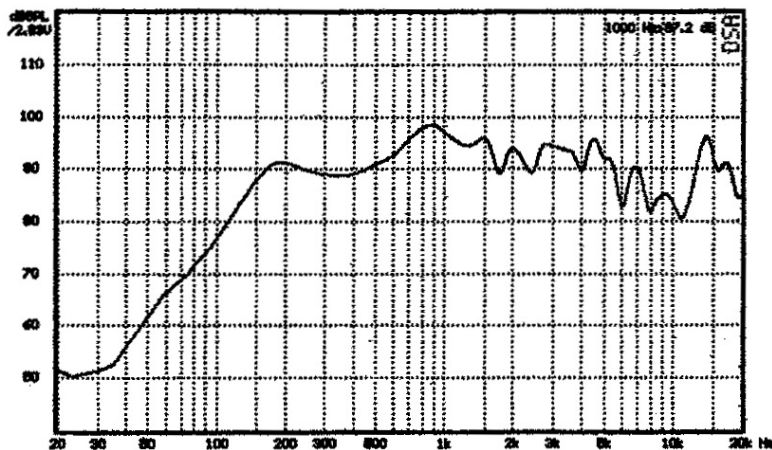

Unit : mm

Z7-39-0520(圖號 D20B06)