

USER'S MANUAL
BEDIENUNGSANLEITUNG
MANUEL D'UTILISATION
MANUAL DE USUARIO
INSTRUKCJA OBSŁUGI
MANUALE D'USO

LDsystems 



ANNY[®] 10

10" PORTABLE BATTERY-POWERED BLUETOOTH[®] PA SYSTEM WITH MIXER
LDANNY10

CONTENTS / INHALTSVERZEICHNIS / CONTENU / CONTENIDO / TREŚĆ / CONTENUTO

ENGLISH

ABOUT THIS MANUAL	4
INTENDED USE	4
EXPLANATIONS OF TERMS AND SYMBOLS	4
SAFETY INSTRUCTIONS	5
NOTES FOR PORTABLE INDOOR EQUIPMENT	10
PACKAGING CONTENT	11
TRANSPORT	12
SMARTPHONE / TABLET TRAY & ACCESSORY COMPARTMENT	13
SETUP	13
CONNECTIONS, CONTROLS AND INDICATORS	14
OPERATION	17
RECEIVER MODULE	21
HANDHELD TRANSMITTER	23
BODYPACK TRANSMITTER	24
CARE, MAINTENANCE AND REPAIR	27
REPLACING DEVICE BATTERIES	28
OPTIONAL ACCESSORIES	30
TECHNICAL DATA	31
DISPOSAL	35
MANUFACTURER'S DECLARATIONS	35

DEUTSCH

INFORMATIONEN ZU DIESER	
BEDIENUNGSANLEITUNG	37
BESTIMMUNGSGEMÄSSER GEBRAUCH	37
BEGRIFFS- UND SYMBOLERKLÄRUNGEN	37
SICHERHEITSHINWEISE	38
HINWEISE FÜR ORTSVERÄNDERLICHE	
INDOOR-GERÄTE	44
LIEFERUMFANG	45
TRANSPORT	46
SMARTPHONE- / TABLET-ABLAGE & ZUBEHÖRFACH	47
AUFBAU	47
ANSCHLÜSSE, BEDIEN- UND ANZEIGEELEMENTE	48
BEDIENUNG	51
EMPFÄNGERMODUL	56
HANDESENDER	57
TASCHESENDER	58
PFLEGE, WARTUNG UND REPARATUR	61
GERÄTEBATTERIEN AUSTAUSCHEN	62
OPTIONALES ZUBEHÖR	64
TECHNISCHE DATEN	65
ENTSORGUNG	69
HERSTELLERERKLÄRUNGEN	70

FRANCAIS

INFORMATIONS SUR CE MODE D'EMPLOI	71
UTILISATION RÉGLEMENTÉE	71
EXPLICATIONS DES TERMES ET DES SYMBOLES	71
CONSIGNES DE SÉCURITÉ	72
NOTES POUR LES ÉQUIPEMENTS PORTABLES	
D'INTÉRIEUR	78
CONTENU DU CARTON	79
TRANSPORT	80
PLATEAU POUR SMARTPHONE / TABLETTE ET COMPARTIMENT POUR ACCESSOIRES	81
INSTALLATION	81
CONNEXIONS, COMMANDES ET INDICATEURS	82
UTILISATION	85
MODULE RÉCEPTEUR	90
ÉMETTEUR À MAIN	91
ÉMETTEUR DE POCHE	92
ENTRETIEN, MAINTENANCE ET RÉPARATIONS	95
REMPLACEMENT DES PILES/BATTERIES	
DE L'APPAREIL	96
ACCESSOIRES EN OPTION	98
CARACTÉRISTIQUES TECHNIQUES	99
MISE AU REBUT	104
DÉCLARATIONS DU FABRICANT	104

ESPAÑOL

INFORMACIÓN SOBRE ESTAS	
INSTRUCCIONES DE USO	105
USO CONFORME A LA NORMATIVA	105
EXPLICACIONES DE TÉRMINOS Y SIMBOLOS	105
INSTRUCCIONES DE SEGURIDAD	106
NOTAS PARA EQUIPOS PORTÁTILES DE INTERIOR	112
CONTENIDO DEL EMBALAJE	113
TRANSPORTE	114
BANDEJA PARA MÓVIL/TABLETA Y COMPARTIMENTO DE ACCESORIOS	115
INSTALACIÓN	115
CONEXIONES, CONTROLES E INDICADORES	116
FUNCIONAMIENTO	119
MÓDULO RECEPTOR	124
MICRO DE MANO TRANSMISOR	126
TRANSMISOR DE PETACA	127
CUIDADO, MANTENIMIENTO Y REPARACIÓN	130
SUSTITUCIÓN DE LAS BATERÍAS DEL EQUIPO	131
ACCESORIOS OPCIONALES	133
DATOS TÉCNICOS	134
DISPOSICIÓN	138
DECLARACIONES DEL FABRICANTE	139

POLSKI

INFORMACJE DOTYCZĄCE NINIEJSZEJ INSTRUKCJI	
OBSŁUGI	140
STOSOWANIE ZGODNIE Z PRZEPISAMI	140
OBJAŚNIENIA TERMINÓW I SYMBOLI	140
INSTRUKCJE BEZPIECZEŃSTWA	141
UWAGI DOTYCZĄCE PRZENOŚNYCH URZĄDZEŃ	
WEWNĘTRZNYCH	147
ZAWARTOŚĆ OPAKOWANIA	148
TRANSPORT	149
TACKA NA SMARTFON/TABLET I SCHOWEK	
NA AKCESORIA	150
SETUP (KONFIGURACJA)	150
POŁĄCZENIA, ELEMENTY STERUJĄCE I WSKAŹNIKI	151
OBSŁUGA	154
MODUŁ ODBIORNIKA	159
NADAJNIK RĘCZNY	161
NADAJNIK BODYPACK	162
PIELEGNACJA, KONSERWACJA I NAPRAWA	165
WYMIANA BATERII URZĄDZENIA	166
AKCESORIA OPCJONALNE	168
DANE TECHNICZNE	169
DYSPOZYCJA	173
OŚWIADCZENIA PRODUCENTA	174

ITALIANO

INFORMAZIONI SU QUESTE ISTRUZIONI PER L'USO	175
UTILIZZO IN CONFORMITÀ ALLE NORMATIVE	175
SPIEGAZIONI DI TERMINI E SIMBOLI	175
ISTRUZIONI DI SICUREZZA	176
NOTE PER LE APPARECCHIATURE PORTATILI	
PER INTERNI	182
CONTENUTO DELL'IMBALLAGGIO	183
TRASPORTO	184
VASSOIO PER SMARTPHONE E TABLET E	
SCOMPARTO PER GLI ACCESSORI	185
INSTALLAZIONE	185
CONNESSIONI, CONTROLLI E INDICATORI	186
FUNZIONAMENTO	189
MODULO RICEVITORE	194
TRASMETTITORE A MANO	195
TRASMETTITORE BODYPACK	196
CURA, MANUTENZIONE E RIPARAZIONE	199
SOSTITUZIONE DELLE BATTERIE DEL DISPOSITIVO	200
ACCESSORI OPZIONALI	202
DATI TECNICI	203
SMALTIMENTO	207
DICHIARAZIONI DEL PRODUTTORE	208

YOU MADE THE RIGHT CHOICE!

This device was developed and manufactured under high quality requirements to ensure many years of trouble-free operation. This is what LD Systems stands for with its name and many years of experience as a manufacturer of high-quality audio products. Please read these operating instructions carefully so that you can quickly and optimally use your new LD Systems product.

You can find more information about LD Systems on our website WWW.LD-SYSTEMS.COM

ABOUT THIS MANUAL

- Read the safety instructions and the entire manual carefully before commissioning.
- Observe the warnings on the unit and in the operating instructions.
- Always keep the operating instructions within reach.
- If you sell or pass on the appliance, be sure to hand over these operating instructions as well, as they are an essential part of the product.

INTENDED USE

The product is a device for event technology!

The product has been developed for professional use in the field of event technology and is not suitable for use in households!

Furthermore, this product is only intended for qualified users with specialist knowledge of event technology!

Use of the product outside the specified technical data and operating conditions is considered improper use! Liability for damage and third party damage to persons and property due to non-intended use is excluded!

The product is not suitable for:

People (including children) with reduced physical, sensory or mental abilities or lack of experience and knowledge.

Children (Children must be instructed not to play with the device).

EXPLANATIONS OF TERMS AND SYMBOLS

1. **DANGER:** The word DANGER, possibly in combination with a symbol, indicates immediately dangerous situations or conditions for life and limb.
2. **WARNING:** The word WARNING, possibly in combination with a symbol, indicates potentially dangerous situations or conditions for life and limb.
3. **CAUTION:** The word CAUTION, possibly in combination with a symbol, is used to indicate situations or conditions that may lead to injury.
4. **ATTENTION:** The word ATTENTION, possibly in combination with a symbol, refers to situations or states that can lead to damage to property and/or the environment.



This symbol indicates hazards that can cause an electric shock.



This symbol indicates danger spots or dangerous situations.



This symbol indicates danger from hot surfaces.



This symbol indicates danger from high volumes.



This symbol indicates supplementary information on the operation of the product.



This symbol denotes a device that does not contain any user-serviceable parts.



This symbol indicates electrical equipment designed primarily for indoor use.

SAFETY INSTRUCTIONS



DANGER:

1. Do not open or modify the device.
2. If your device is no longer working properly, liquids or objects have gotten inside the device, or the device has been damaged in any other way, switch it off immediately and disconnect it from the power supply. This device may only be repaired by authorized specialist personnel.
3. For devices of protection class 1, the protective conductor must be connected correctly. Never interrupt the protective conductor. Protection class 2 devices do not have a protective conductor.
4. Ensure that live cables are not kinked or otherwise mechanically damaged.
5. Never bypass the device fuse.



WARNING:

1. The device must not be put into operation if it shows obvious signs of damage.
2. The device may only be installed in a voltage-free state.
3. If the power cord of the device is damaged, the device must not be put into operation.
4. Permanently connected power cords may only be replaced by a qualified person.

**DANGER:**

1. Do not operate the device if it has been exposed to severe temperature fluctuations (e.g. after transport). Humidity and condensation could damage the device. Do not switch on the device until it has reached the ambient temperature.
2. Make sure that the voltage and frequency of the mains supply correspond to the values indicated on the device. If the device has a voltage selector switch, do not connect the device until this is set correctly. Only use suitable power cords.
3. To disconnect the device from the mains at all poles, it is not enough to press the on/off switch on the device.
4. Ensure that the fuse used corresponds to the type printed on the device.
5. Make sure that appropriate measures against overvoltage (e.g. lightning) have been taken.
6. Note the specified maximum output current on devices with a power out connection. Make sure that the total power consumption of all connected devices does not exceed the specified value.
7. Only replace pluggable power cords with original cables.
8. Operation only on currently compliant, tested and intact mains connection equipment.

**DANGER:**

1. Danger of suffocation! Plastic bags and small parts must be kept out of the reach of people (including children) with reduced physical, sensory or mental abilities.
2. Danger from falling! Make sure the device is installed securely and cannot fall. Only use suitable tripods or attachments (especially for fixed installations). Make sure accessories are properly installed and secured. Make sure that the applicable safety regulations are observed.

**WARNING:**

1. Only use the device in the manner intended.
2. Only operate the device with the accessories recommended and intended by the manufacturer.
3. During installation, observe the safety regulations applicable in your country.
4. After connecting the unit, check all cable routes to avoid damage or accidents, e.g. due to tripping hazards.
5. Be sure to observe the specified minimum distance to normally flammable materials! Unless this is explicitly stated, the minimum distance is 0.3 m.

**ATTENTION:**

1. In the case of moving components such as mounting brackets or other moving components, there is a possibility of jamming.

**DANGER:**

1. Do not install or operate the device near radiators, heat registers, stoves or other heat sources. Make sure that the device is always installed in such a way that it is sufficiently cooled and cannot overheat.
2. Do not place any sources of ignition such as burning candles near the device.
3. Ventilation openings must not be covered and fans must not be blocked.
4. Use the original packaging or packaging provided by the manufacturer for transport.
5. Avoid shock or shock to the device.
6. Observe the IP protection class and the environmental conditions such as temperature and humidity according to the specification.
7. Devices can be continuously developed. In the event of deviating information on operating conditions, performance or other device properties between the operating instructions and the device labeling, the information on the device always has priority.
8. The device is not suitable for tropical climate zones and for operation above 2000 m above sea level.

**ATTENTION:**

Connecting signal cables can result in significant noise interference. Make sure that devices connected to the output are muted during plugging. Otherwise, noise levels can cause damage.

**ATTENTION HIGH VOLUMES WITH AUDIO PRODUCTS!**

This device is intended for professional use.

The commercial operation of this device is subject to the applicable national regulations and guidelines for accident prevention.

Hearing damage due to high volumes and continuous exposure: The use of this product can generate high sound pressure levels (SPL) which can cause hearing damage. Avoid exposure to high volumes.

**SIGNAL TRANSMISSION VIA RADIO (e.g. W-DMX or audio radio systems, Bluetooth):**

The quality and performance of wireless signal transmissions generally depends on the environmental conditions.

Influence on the range and signal stability, for example:

- Shielding (e.g. masonry, metal structures, water)
- High radio traffic (e.g. strong W-LAN networks)
- Interference
- Electromagnetic radiation (e.g. LED video walls, dimmers)

All range specifications refer to free field use with visual contact without interference!

The operation of transmitters is subject to official regulations. These can vary from region to region and must be checked by the operator before commissioning (e.g. radio frequency and transmission power).

**WARNING:**

Devices with wireless signal transmission are not suitable for operation in sensitive areas in which radio operation can lead to possible interactions. These include, for example:

- Hospitals, health centers or other healthcare facilities that perform patient treatments with specialized staff and equipment.
- Class I, II and III hazardous areas
- restricted areas
- military facilities
- airplanes or vehicles
- Areas where cell phone use is prohibited

**DEVICES WITH RECHARGEABLE BATTERIES, BATTERIES AND CHARGERS****DANGER:**

1. Keep the appliance with battery away from heat sources and do not expose it to direct sunlight. Do not place it on or in heating appliances such as microwaves, ovens or radiators. Batteries can explode if overheated. Be sure to observe the permissible ambient and operating conditions! These can be found in the technical specifications.
2. Battery cells or battery packs must not be damaged. Protective foils and stickers must not be removed. No foreign objects may be inserted into the battery. No liquids may get into the battery. There is a risk of fire and explosion as well as other dangerous situations (e.g. outgassing).
3. If the unit is deformed or overheated, put the unit out of operation immediately! If you continue to operate the unit, there is a risk of fire, explosion and other dangerous situations (e.g. outgassing).
4. Do not throw the unit into a fire! Danger of explosion!
5. Avoid strong mechanical impacts on the unit! Damage due to falling, smashing or piercing as well as high pressure leads to fire and explosion hazards as well as the risk of further dangerous situations (e.g. outgassing).
6. Only charge the device or the battery in the intended manner. Only use the original charger. Please note that a compatible plug connection does not indicate the suitability of the charger.
7. Please note that the charging function is not deactivated by the main unit switch on all units.
8. In the case of charging devices integrated in transport cases, the charging process may only be carried out with the lid open.
9. Spilled liquid is corrosive and may be toxic. It can cause skin and eye irritation and is dangerous if swallowed. Avoid any contact with spilled liquid. In case of contact with spilled liquid, wash the affected area immediately with plenty of water and contact a doctor.



DEVICES WITH BATTERY REPLACEMENT PROVIDED BY THE USER

DANGER:

Be sure to observe the manufacturer's data sheet for the batteries or rechargeable batteries used!

1. Batteries and rechargeable batteries must be kept out of reach of persons (including children) with reduced physical, sensory or mental capabilities. Danger of suffocation!
2. Avoid strong mechanical impacts on batteries and accumulators! Damage due to falling, smashing or puncturing as well as high pressure leads to fire and explosion hazards as well as the risk of further dangerous situations (e.g. outgassing).
3. Leaking battery fluid is corrosive and can be toxic. It can cause skin and eye irritation and is dangerous if swallowed. Avoid any contact with leaked fluid. In case of contact with leaked liquid, wash the affected area immediately with plenty of water and contact a doctor.
4. Never attempt to charge non-rechargeable batteries. Danger of explosion!
5. Do not throw batteries and rechargeable batteries into a fire! Danger of explosion!
6. Do not short-circuit batteries and rechargeable batteries! Avoid contact of the battery terminals with electrically conductive objects (e.g. key ring, coins, tools).



CAUTION:

1. When inserting batteries and rechargeable batteries, ensure that the polarity is correct (see illustrations in the battery compartment or on the housing).
2. Do not use different cell types and battery brands in the same unit at the same time.
3. Only use batteries and rechargeable batteries with the same discharge status.
4. Check batteries and rechargeable batteries for damage and do not use damaged batteries and rechargeable batteries!



CHARGING, OPERATING AND STORING BATTERIES

1. To charge permanently installed batteries, connect the unit to the designated power supply. Please note that the charging function is not deactivated by the main unit switch on all units.
2. Please refer to the technical data for the charging time required to fully charge the battery. The information about the battery charge status can be found in the OPERATION chapter.
3. Units with lithium batteries are equipped with the usual protective devices.
4. Do not charge batteries outside the ambient conditions specified in the technical data. Unless otherwise stated, these are between +5° and +35° Celsius in a dry environment.
5. The permissible ambient conditions for operation can be found in the technical data. Unless otherwise specified, the temperature must not fall below +5°C and must not exceed +35°C in a dry environment.
6. The permissible ambient temperature for storage can be found in the technical data. Unless otherwise stated, the temperature must not fall below +5°C and must not exceed +35°C in a dry environment.
7. After discharging, fully charge the battery again as soon as possible.
8. Only store the unit with a fully charged battery. Batteries that are not fully charged when stored can lose capacity and life prematurely.
9. If the unit is not used for a long period of time, perform a full recharge cycle at least every 3 months.
10. The main switch of the unit must be switched off during storage.
11. Specified battery runtimes always refer to a new battery and normal operating conditions.
12. When operating in a cold environment, the battery life may be shorter than indicated.
13. If the device runtime in battery mode deviates significantly from the specifications, contact your sales partner.



NOTES FOR PORTABLE INDOOR EQUIPMENT

1. Temporary operation! Event equipment is basically only designed for temporary operation.
2. Continuous operation or permanent installation can lead to impairment of the function and premature ageing of the equipment.

PACKAGING CONTENT

Remove the product from the packaging and remove all packaging material. Please check the completeness and integrity of the delivery and notify your distribution partner immediately after purchase if the delivery is not complete or if it is damaged.

The packaging content of the **ANNY 10** product includes:

- 1 x ANNY 10 loudspeaker
- 1 x power cable
- User's manual

The packaging content of the **ANNY 10 HHD** product includes:

- 1 x ANNY 10 loudspeaker
- 1 x handheld transmitter + 2 x AA battery
- 1 x receiver module + antenna
- 1 x power cable
- User's manual

The packaging content of the **ANNY 10 HHD 2** product includes:

- 1 x ANNY 10 loudspeaker
- 2 x handheld transmitters + 4 x AA battery
- 2 x receiver module + antenna
- 1 x power cable
- User's manual

The packaging content of the **ANNY 10 BPH** product includes:

- 1 x ANNY 10 loudspeaker
- 1 x body pack transmitter + headset + 2 x AA battery
- 1 x receiver module + antenna
- 1 x power cable
- User's manual

The packaging content of the **ANNY 10 BPH 2** product includes:

- 1 x ANNY 10 loudspeaker
- 2 x body pack transmitter + headset + 4 x AA battery
- 2 x receiver module + antenna
- 1 x power cable
- User's manual

The packaging content of the **ANNY 10 HBH 2** product includes:

- 1 x ANNY 10 loudspeaker
- 1 x handheld transmitter + 2 x AA battery
- 1 x body pack transmitter + headset + 2 x AA battery
- 2 x receiver module + antenna
- 1 x power cable
- User's manual

FEATURES

- Portable and battery-powered all-in-one audio solution
- Integrated 6-channel mixer with system presets, 3-band EQ and effects (Reverb & Delay)
- DynX® DSP (Gen.2) for distortion-free sound even at maximum volume
- Two receiver slots for wireless microphones or bodypacks
- Two switchable mic or line inputs
- Up to 5 hours battery life at maximum volume, 20 hours at moderate volume
- Priority/ducking mode to highlight microphone signal
- Built-in wheels and retractable handle for easy portability
- 35 mm flange for applications on a speaker pole
- AAC coding for HD Bluetooth® 5.0 streaming
- True Wireless Stereo (TWS) to connect two ANNYS and enjoy true stereo streaming
- USB-C port for charging your mobile devices
- Integrated holder for tablet or phone
- Footswitch input for easy and hands-free control of effects

TRANSPORT

Thanks to the practical castors **1** and the extendable trolley handle **2**, the portable speaker is easy to transport. Switch off the speaker, remove all connected cables, place the speaker on the floor and press the marked area in the middle of the handle **3** to unlock it. Now pull the handle out of the speaker housing as far as it will go. To lower the handle, again press on the marked area in the handle and push the handle into the housing as far as it will go. For lifting and carrying the speaker, there is an ergonomically shaped carrying handle **4** behind the trolley handle and additionally two handles on the sides of the housing **5**.

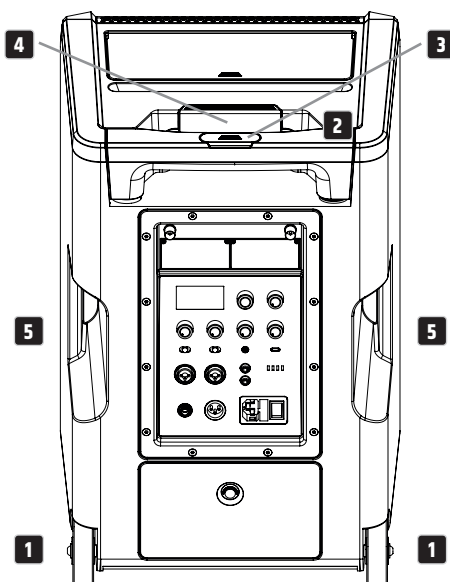

ATTENTION: Avoid rolling the speaker over uneven surfaces such as cobblestones. Also avoid rolling the speaker over steps. Strong mechanical shocks can damage the castors, the cabinet and the internal components.



SMARTPHONE / TABLET TRAY & ACCESSORY COMPARTMENT

The smartphone or tablet tray **1** is located between the transport handle and the accessory compartment. To open the accessory compartment, press the mark on the accessory compartment cover **2**. The accessory compartment has space for handheld and bodypack transmitters as well as other accessories such as antennas for the receivers **3**. To close the lid again, press it onto the accessory compartment until it clicks into place.

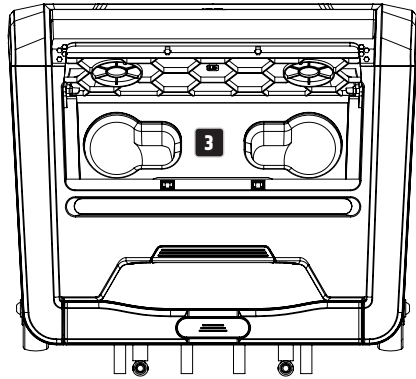
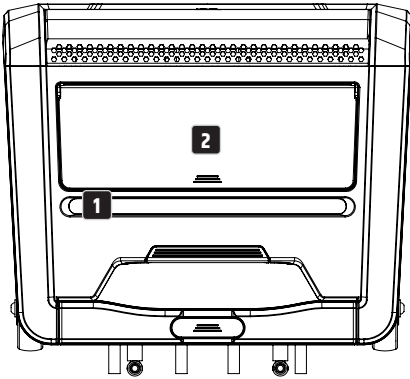

SETUP



DANGER: Always place the loudspeaker in a suitable location on a sufficiently stable, level and horizontal surface. Make sure that the speaker cannot fall off the edge of a stage (e.g. due to vibration). When using a stand, make sure that it is suitable for the weight and speaker flange of the speaker. The tripod must stand vertically on solid ground and the maximum permissible height must not be exceeded. There is a risk that equipment that has not been set up and positioned correctly will fall over or down. This can cause serious injury or death.

CONNECTIONS, CONTROLS AND INDICATORS

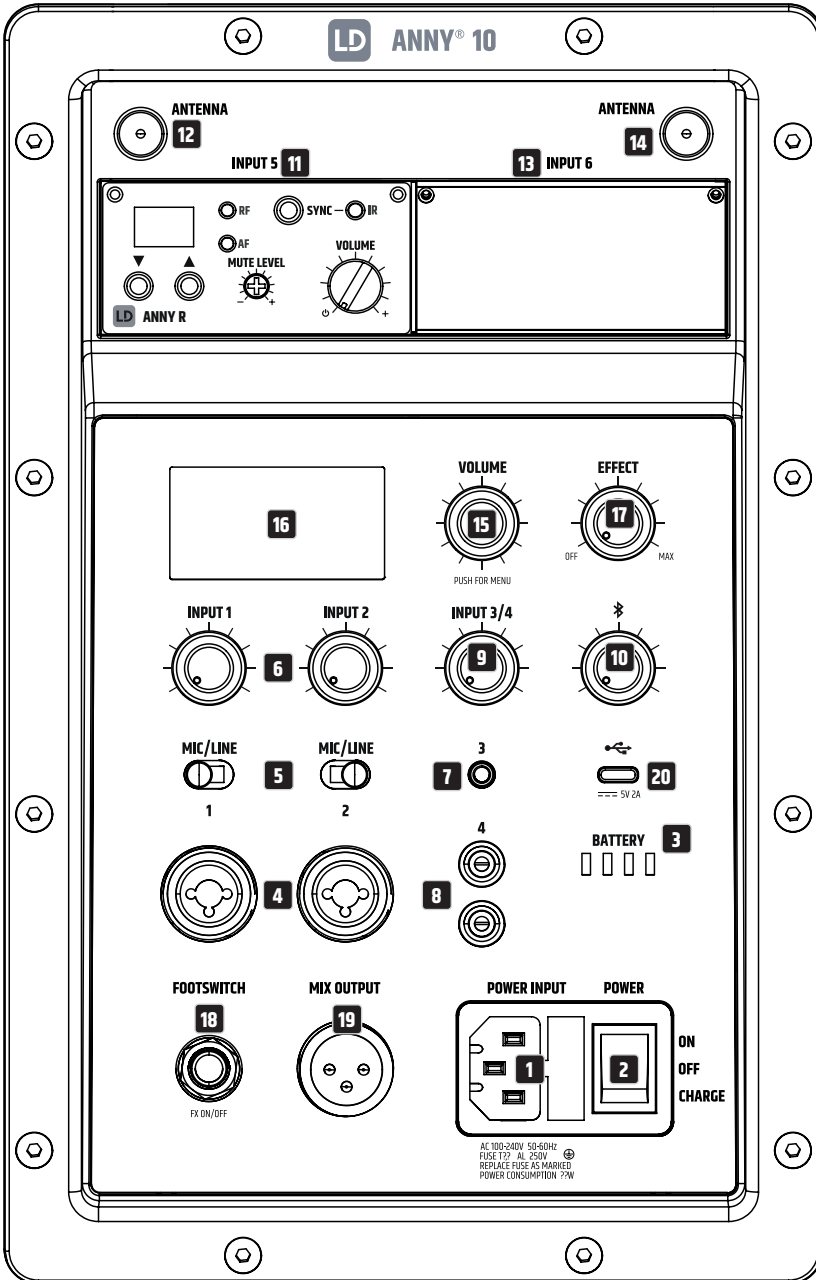

1 POWER INPUT

IEC mains socket with integrated fuse holder. A suitable power cable is included in the delivery.

- Use the mains input to operate and charge the internal batteries at the same time by setting the POWER switch to the ON position.
- Use the mains input to charge the internal batteries without operating the unit. To do this, set the POWER switch to the CHARGE position.

WARNING: Replace the fuse only with a fuse of the same type and with the same values. Pay attention to the imprint on the housing. If the fuse blows repeatedly, please contact an authorised service centre.

2 POWER

Switch in **ON** position: Unit switched on. The internal batteries can also be charged during operation using the mains cable supplied.

Switch in **OFF** position: Unit switched off.

Switch in **CHARGE** position: Unit switched off and in charging mode.

3 BATTERY

4-segment battery charge status display. 4 LEDs lit = 100 %, 3 LEDs lit = 75 %, 2 LEDs lit = 50 %, 1 LED lit = 25 %. If only the first LED flashes: Below 10 %. Please connect the unit to the mains immediately for charging.

4 INPUT 1 & 2 – AUDIO INPUT

Audio input for channel 1 or 2, equipped with combo sockets (3-pin XLR / 6.3 mm jack). The audio inputs are suitable for both balanced and unbalanced cabling.

5 INPUT 1 & 2 – MIC / LINE

Switch for adjusting the input sensitivity for channel 1 or 2.

Connection of a microphone: MIC position.

Connection of a line level player: LINE position.

6 INPUT 1 & 2 – VOLUME

Turn the level control to adjust the volume of channel 1 or 2. Turn counterclockwise: Decrease volume. Turn clockwise: Increase volume.

7 INPUT 3

Unbalanced stereo line input with a 3.5 mm jack socket for connecting an audio player, e.g. an MP3 player. The input sockets of INPUT 3 and INPUT 4 are wired in parallel and can be used simultaneously. An incoming stereo signal is internally summed mono.

8 INPUT 4

Unbalanced stereo line input with two RCA sockets for connecting an audio player, e.g. a CD player or keyboard. The input sockets of INPUT 3 and INPUT 4 are wired in parallel and can be used simultaneously. An incoming stereo signal is internally summed mono.

9 INPUT 3/4 – VOLUME

Level control to adjust the volume of channel 3 and 4. Turn counterclockwise: decrease volume. Turn clockwise: Increase volume.

10 BLUETOOTH – VOLUME

Level control for adjusting the volume of a Bluetooth accessory device, e.g. smartphone. Turn counterclockwise: Decrease volume. Turn clockwise: increase volume (pair Bluetooth accessory, see OPERATION – BLUETOOTH SETTINGS).

11 INPUT 5

Mounting slot with audio input for a receiver module for channel 5. The volume of the channel is controlled by a volume control in the receiver module.

12 ANTENNA

BNC socket for connecting an antenna for the receiver module of INPUT 5 (a suitable antenna is included with the receiver module).

13 INPUT 6

Mounting slot with audio input for a receiver module for channel 6. The volume of the channel is controlled by a volume control in the receiver module.

14 ANTENNA

BNC socket for connecting an antenna for the receiver module of INPUT 6 (a suitable antenna is included with the receiver module).

15 VOLUME / PUSH FOR MENU

Rotary-push encoder with multiple function.

- Starting from the main display, the overall volume can be adjusted directly by turning the rotary-push encoder. Counterclockwise rotation: Decrease volume. Clockwise rotation: Increase volume. Before playing back audio data or using a microphone, set the overall volume to minimum and then increase the volume only slowly to avoid damage to the unit or hearing damage due to sudden high volume levels and feedback.
- Press the rotary-push encoder to enter the main menu. Navigate in the main menu using the turn-push encoder, select the desired submenu item by turning the encoder, confirm by pressing the encoder, adjust system settings and change values in the corresponding menu items (see OPERATION; change value or status = turn encoder, confirm value or status change = press encoder).

16 DISPLAY

Multifunctional graphic LC display for showing overall volume, speaker and effect preset, Bluetooth and battery status, and input level for channels 1, 2, 3/4 and 5/6 in the main display. The edit menu shows the menu items, the submenu items and the corresponding edit options. Brightness, contrast and switch-off of the display illumination are adjustable.

17 EFFECT

Level control for adjusting the effect volume (effect return). The effect type and the effect sends are set in the unit menu under EFFECT.

18 FOOTSWITCH FX ON/OFF

6.3 mm jack socket for connecting a footswitch (on/off switch). With an external footswitch with a 6.3 mm jack plug, you can mute the internal effect module and unmute it again.

19 MIX OUTPUT

Balanced line output with male 3-pin XLR socket. The outgoing signal consists of a mix of all input channels plus effect and Bluetooth signal and is independent of the overall volume setting.

20 USB-C

USB-C socket for charging a smartphone or tablet (5 volts voltage, maximum 2 A charging current).

OPERATION

NOTES

As soon as the speaker is switched on (with sufficient battery status or power supply via mains cable), the LD Systems logo appears in the display for a short time. All settings, such as preset, EQ and effect, are loaded as they were set before the speaker was switched off. After this process, the speaker is ready for operation.

MAIN DISPLAY

In normal operation, the main display is activated and shows the set overall volume, the activated speaker preset, the effect preset, the input levels of channels 1 to 6, the Bluetooth and TWS status and the battery charge status (see illustration).

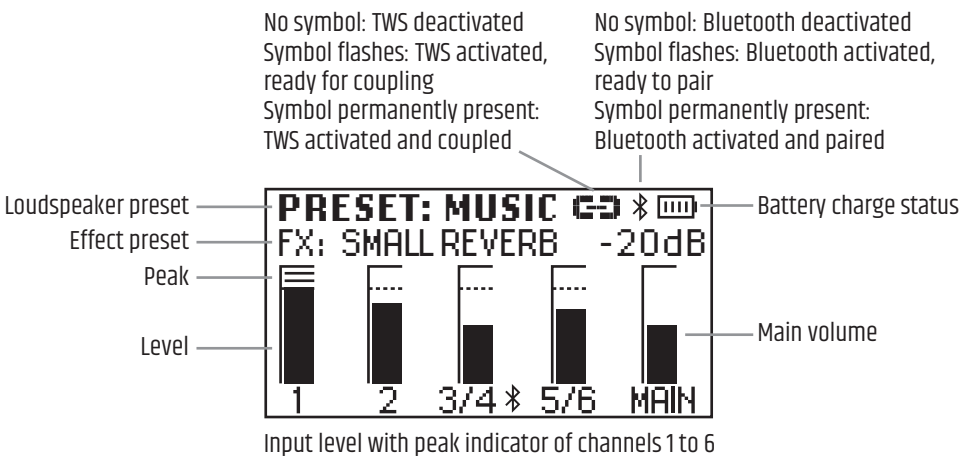

PEAK INDICATOR

If the peak symbol appears in the level display of a channel, this indicates that the input stage of the corresponding channel is operated above the distortion limit. Reduce the output level of the connected playback device (e.g. mixer, keyboard, etc.) until the peak symbol is no longer displayed and the loudspeaker plays back audio signals without distortion.

MAIN VOLUME

Starting from the main display, the overall volume can be adjusted directly by turning the rotary-push encoder VOLUME / PUSH FOR MENU. The display changes automatically when the encoder is turned (see illustration below). After about 10 seconds of inactivity, the main display is automatically shown again; by pressing the encoder, the display immediately changes to the main display.



BLUETOOTH SETTINGS (BLUETOOTH)

Press the rotary-push encoder to enter the main menu and then select the **BLUETOOTH** menu item by turning the encoder (dark background). Press the encoder again to enter the submenu and select the desired submenu item by turning the encoder. Confirm by pressing the encoder. Refer to the following table for information on the submenu items. Select **MAIN MENU** in the submenu and press the encoder to return to the main menu, select **HOME** in the main menu, confirm by pressing the encoder, and then return to the main display. After about 10 seconds of inactivity, the main display is automatically shown.

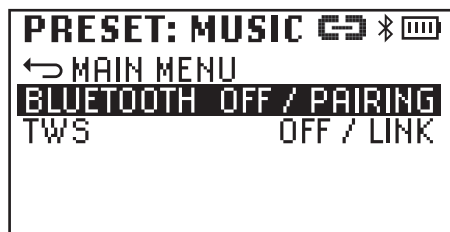
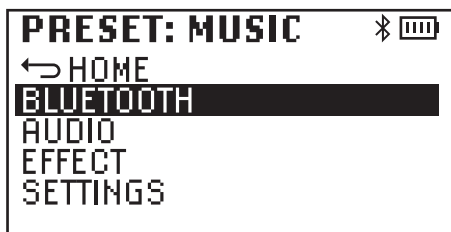

Pairing with an Bluetooth playback device: Select **BLUETOOTH** in the Bluetooth menu, confirm, then select **PAIRING** and confirm again. The Bluetooth module is now ready for pairing. The Bluetooth symbol flashes for the duration of the pairing readiness. Activate Bluetooth on your playback device (smartphone, tablet, etc.) and select **ANNY 10** in the Bluetooth menu. Pairing now takes place automatically. As soon as the devices are paired, the Bluetooth symbol is permanently displayed and **PAIRED** is shown in the Bluetooth menu. Audio playback via Bluetooth can now be started.

BLUETOOTH (Change status = turn encoder, confirm status change = press encoder)		
BLUETOOTH	Activate Bluetooth	PAIRING
	Deactivate Bluetooth	OFF
TWS	Activate TWS	LINK
	Deactivate TWS	OFF

The LD ANNY 10 speaker can be operated in mono or stereo mode. In mono mode, a stereo signal applied to a stereo input or transmitted via Bluetooth is internally summed to mono. If two ANNY 10 speakers are connected wirelessly using the TWS function, the system paired with the Bluetooth input device becomes the main unit (stereo left) and the stereo extension becomes the follower unit (stereo right). This means that all stereo signals transmitted via Bluetooth are also reproduced in stereo without having to connect both speakers by cable. To connect via TWS, simply activate TWS in both units (LINK), the connection is now automatic and LINKED (= connected) is displayed in the Bluetooth menu.



NOTE:

- Only audio signals played on a paired Bluetooth playback device can be transmitted via the stereo link function TWS. Audio signals that are present at a physical input are not transmitted via TWS.
- After switching the ANNY 10 speakers off and on again, both the connection to the Bluetooth playback device and the connection of the speakers via TWS take place automatically.

AUDIO SETTINGS (AUDIO)

Press the rotary-push encoder to enter the main menu and then select the **AUDIO** menu item by turning the encoder (dark background). Press the encoder again to enter the submenu and select the desired submenu item by turning the encoder. Confirm by pressing the encoder. Refer to the following table for information on the submenu items. Select -MAIN MENU in the submenu and press the encoder to return to the main menu, select -HOME in the main menu, confirm by pressing the encoder, and then return to the main display. After about 10 seconds of inactivity, the main display is automatically shown.

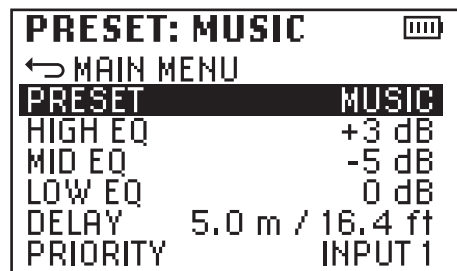
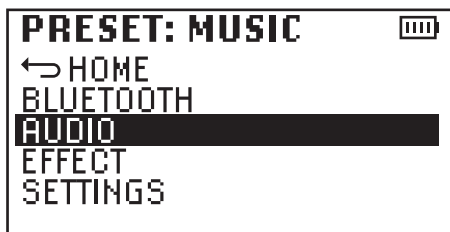

AUDIO (Change value or status = turn encoder, confirm value or status change = press encoder)		
↩ MAIN MENU	Back to main menu	
PRESET	Speaker preset selection	MUSIC
		VOCAL
		LIVE
		ECO
		OFF
HIGH EQ	Adjust treble frequencies from -12dB to +12dB	
MID EQ	Adjust mid frequencies from -12dB to +12dB	
LOW EQ	Adjust bass frequencies from -12dB to +12dB	
DELAY	Time delay of the sum signal in 0.5 m steps up to 10 m, e.g. for a delay line (0 m = OFF, display in metres and feet).	
PRIORITY	Priority circuit for the inputs INPUT 1, 2 or 5/6. If an input is assigned priority and a signal is present at it, the volume of the other inputs is automatically reduced. If the signal is no longer present, the volume of the other channels is raised again to the original value after a few seconds (no multiple selection possible, OFF = function deactivated).	INPUT 1
		INPUT 2
		INPUT 5/6
		OFF

EFFECT SETTINGS (EFFECT)

Press the rotary-push encoder to enter the main menu and then select the menu item **EFFECT** by turning the encoder (dark background). Press the encoder again to enter the submenu and select the desired submenu item by turning the encoder. Confirm by pressing the encoder. Refer to the following table for information on the submenu items. Select **MAIN MENU** in the submenu and press the encoder to return to the main menu, select **HOME** in the main menu, confirm by pressing the encoder, and then return to the main display. After about 10 seconds of inactivity, the main display is automatically shown.

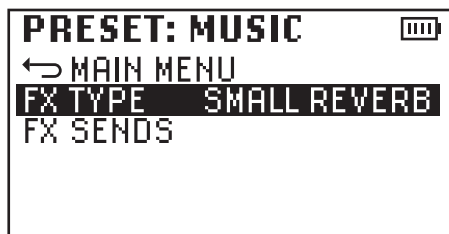
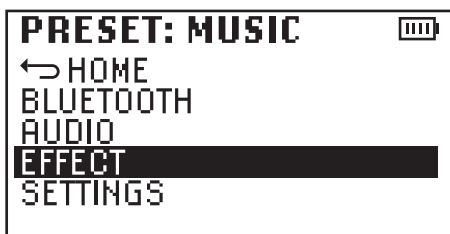

EFFECT (Change value or status = turn encoder, confirm value or status change = press encoder)			
FX TYPE	Selecting the effect type or switching off the effect (OFF)	SMALL REVERB	
		LARGE REVERB	
		PLATE REVERB	
		DELAY	
		OFF	
FX SENDS	Setting the effect sends for inputs INPUT 1, 2 and 5/6	INPUT 1	0 - 100%
		INPUT 2	0 - 100%
		INPUT 5/6	0 - 100%

SYSTEM SETTINGS (SETTINGS)

Press the rotary-push encoder to enter the main menu and then select the **SETTINGS** menu item by turning the encoder (dark background). Press the encoder again to enter the submenu and select the desired submenu item by turning the encoder. Confirm by pressing the encoder. Refer to the following table for information on the submenu items. Select -MAIN MENU in the submenu and press the encoder to return to the main menu, select -HOME in the main menu, confirm by pressing the encoder, and then return to the main display. After about 10 seconds of inactivity, the main display is automatically shown.

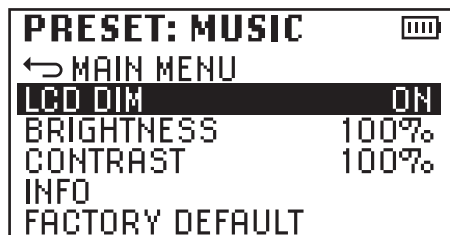
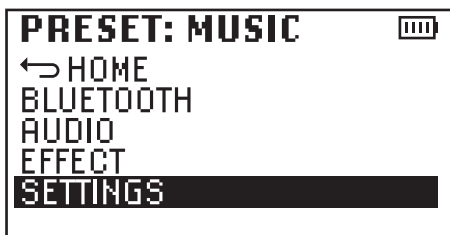

SETTINGS (Change value or status = turn encoder, confirm value or status change = press encoder)		
LCD DIM	Display illumination is switched off after approx. 10 s without input	ON
	Display illumination permanently switched on	OFF
BRIGHTNESS	Adjust the display brightness from 0 - 100%	0 - 100%
CONTRAST	Adjust the contrast from 0 - 100%	0 - 100%
INFO	Display of the model name and the unit software version	MODEL: ANNY 10
		SOFTWARE: 1.x
FACTORY DEFAULT	Reset to factory default settings:	RESET -> SURE? -> YES
	Cancel procedure:	1. CANCEL 2. RESET -> SURE? -> CANCEL

RECEIVER MODULE

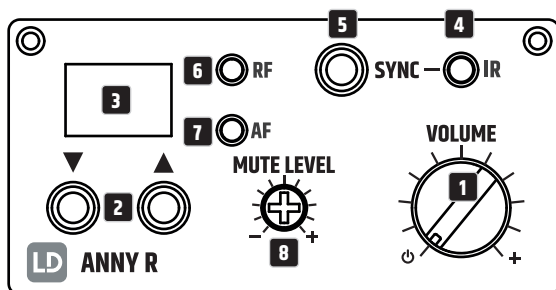

1 VOLUME

Turn the control clockwise over the detent to switch the receiver on, another clockwise turn raises the volume, counterclockwise turn lowers it. Turn the control counterclockwise over the detent to switch off the receiver.

2 ▲ ▼

Select one of the 12 available radio channels by pressing the arrow keys ▲ or ▼ repeatedly, if necessary.

3 LED DISPLAY

The selected radio channel is shown in the display (01 – 12).

4 IR

Infrared interface for synchronising the radio channel of the receiver and handheld or pocket transmitter.

5 SYNC**Synchronising receiver and handheld transmitter**

To synchronise the radio channel of the receiver and the hand-held transmitter, select the desired radio channel on the receiver, switch on the hand-held transmitter and then press the SYNC button while pointing the infrared interface of the hand-held transmitter in direct visual contact with the infrared interface of the receiver. The infrared interface of the hand-held transmitter is located on the underside of the hand-held transmitter. If the synchronisation was successful, the red indicator LED RF on the receiver will now light up.

Synchronising receiver and bodypack transmitter

To synchronise the radio channel of the receiver and the bodypack transmitter, select the desired radio channel on the receiver, switch on the bodypack transmitter and then press the SYNC button while pointing the infrared interface of the bodypack transmitter in direct visual contact with the infrared interface of the receiver. The infrared interface for synchronising the radio channel of the receiver and transmitter is located in the battery compartment. To open the battery compartment, press both markings on the sides of the battery compartment cover simultaneously and fold it forwards. If the synchronisation was successful, the red RF indicator LED on the receiver lights up.

6 RF indicator LED

As soon as there is a radio connection between the transmitter and receiver, the red RF LED lights up.

7 AF indicator LED

The green AF LED indicates an audio signal is present.

8 MUTE LEVEL

CAUTION: Before changing the mute level, first set the volume of the speaker to minimum. The mute function (noise reduction / squelch) prevents interference noises from occurring when the transmitter is switched off. In addition, suddenly occurring noise is also suppressed if the signal transmitted from the transmitter to the receiver is not strong enough (e.g. due to too great a distance between transmitter and receiver). With the transmitter switched off, adjust the mute level with a suitable screwdriver so that background noise is just effectively suppressed (turned to the left, noise suppression is reduced, turned to the right, it is increased). In the case of the setting with strong noise suppression, the transmission range can be reduced under unfavorable circumstances. The Mute Level control is in the delivery state on the left stop, the noise suppression thus on minimum strength. This setting is suitable for the majority of all applications and changes are only required in rare cases.

HANDHELD TRANSMITTER

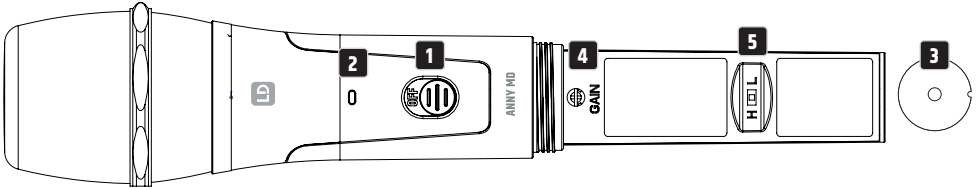

1 ON / OFF

On or off switch. Slide the switch upwards to switch the handheld transmitter on; the word „ON“ can now be read below the switch. Slide the switch downwards to switch the hand-held transmitter off (OFF).

2 STATUS LED

If the charging status of the inserted batteries is sufficient, the LED lights up green when the handheld transmitter is switched on. If the LED lights up red, the charging status is low. Replace the used batteries immediately.

3 IR INTERFACE

The infrared interface for synchronising the radio channel of the receiver and transmitter is located on the underside of the handheld transmitter (for synchronisation procedure, see RECEIVER MODULE - SYNC).

4 SENSITIVITY CONTROL (INPUT SENSITIVITY)

Turn to the left: Decrease the input sensitivity
Turn to the right: Increase the input sensitivity

5 HF SWITCH (SETTING THE TRANSMISSION POWER)

Position „H“: high; Position „L“: low

REPLACING THE BATTERIES

To replace the batteries, open the battery compartment of the handheld transmitter by loosening the battery compartment cover by turning it counterclockwise and pulling it off the housing. Remove the used batteries and insert fresh batteries (2 x type AA / LR6, alkaline) according to the illustrations in the battery compartment. Place the battery compartment cover on the housing and close the battery compartment by turning it clockwise. If you are not going to use the transmitter for a longer period of time, please remove the batteries to avoid damage to the transmitter due to leaking batteries.

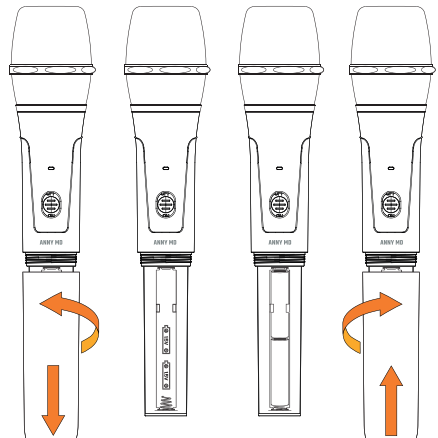

BODYPACK TRANSMITTER

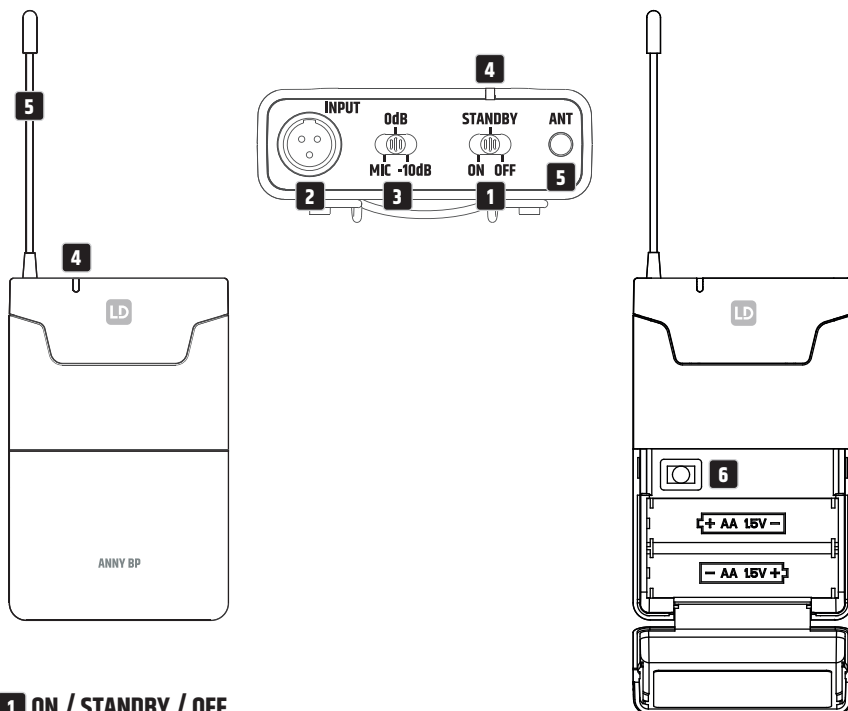

1 ON / STANDBY / OFF

Switch for switching the pocket transmitter on or off (ON = transmitter switched on, OFF = transmitter switched off). In the STANDBY position, the transmitter is in operation but the audio signal is muted.

2 INPUT

3-pin mini-XLR jack for connecting a headset or lavalier or instrument microphone and a guitar cable.

3 MIC / 0dB / -10dB

Adjust the input sensitivity. Set the sensitivity so that when a signal is present (speech, vocals, guitar ...) the AF LED of the receiver lights up green. As soon as the audio signal begins to distort, reduce the sensitivity by setting the 3-step switch MIC / 0dB / -10dB to the next lower value.

Examples: Headset = MIC, guitar with passive pickup = 0dB, guitar with active pickup = -10dB.

4 STATUS LED

If the charging status of the inserted batteries is sufficient, the LED lights up green when the transmitter is switched on. If the LED lights up red, the charging status is low. Replace the used batteries immediately.

5 ANTENNA

Antenna of the bodypack transmitter. For optimum reception, do not cover or bend.

6 IR INTERFACE

The infrared interface for synchronising the radio channel of the receiver and transmitter is located in the battery compartment. To open the battery compartment, press both markings on the sides of the battery compartment cover at the same time and flip it forward (for synchronisation procedure, see RECEIVER MODULE – SYNC).

REPLACING THE BATTERIES

To replace the batteries, open the battery compartment of the bodypack transmitter by simultaneously pressing on both markings on the sides of the battery compartment cover and folding it forward. Remove the used batteries and insert fresh batteries (2x type AA / LR6, alkaline) according to the illustrations in the battery compartment. Now fold the battery compartment cover back onto the housing until the cover clicks into place. If you are not going to use the transmitter for a longer period of time, please remove the batteries to avoid damage to the transmitter due to leaking batteries.

ATTACHING THE BODYPACK TRANSMITTER

Attach the transmitter to a belt or strap as shown.

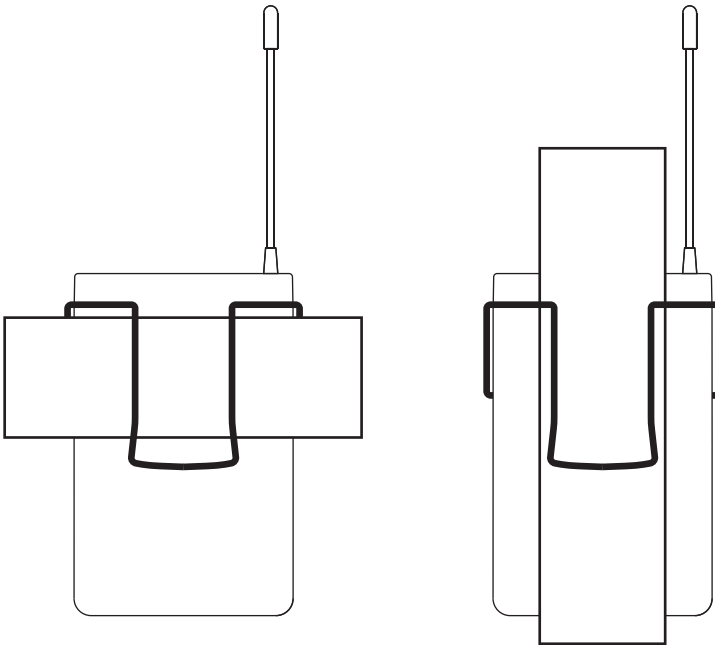

PIN ASSIGNMENT MINI-XLR INPUT

Electric guitar, electric bass and other high-impedance signal sources



Condenser microphone with internal pull-up resistor



Condenser microphone without internal pull-up resistor

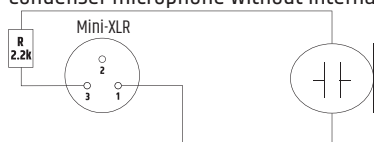

CARE, MAINTENANCE AND REPAIR

In order to ensure the long-term, proper functioning of the device, it must be regularly cleaned and, if necessary, maintained. The maintenance requirement depends on the intensity of use and the environment in which it is used. We generally recommend a visual inspection before each operation. Furthermore, we recommend carrying out all the applicable maintenance measures specified below once every 500 operating hours or, in the case of a lower intensity of use, at the latest after one year. Warranty claims may be limited in the event of defects resulting from inadequate maintenance.

CARE (CARRIED OUT BY THE USER)



WARNING! Before carrying out any maintenance work, the power supply and, if possible, all device connections must be unplugged.



PLEASE NOTE! Improper care can lead to impairment of the device or even destruction.

1. Housing surfaces must be cleaned with a clean, damp cloth. In doing so, ensure that no moisture can penetrate into the device.
2. Air inlets and outlets must be regularly cleaned of dust and dirt. If compressed air is used, care must be taken to ensure that damage to the device is prevented (e.g. fans must be blocked in this case, as they could otherwise over-rev).
3. Lines and plug contacts must be cleaned regularly and dust and dirt must be removed.
4. In general, no cleaning agents or abrasive agents may be used, otherwise the surface finish may be damaged.
5. Devices must generally be stored dry and protected from dust and dirt.

MAINTENANCE AND REPAIR (BY QUALIFIED PERSONNEL ONLY)



DANGER! There are live components in the device. Even after disconnecting the mains connection, there may still be residual voltage in the device, e.g. due to charged capacitors.



PLEASE NOTE! There are no user-serviceable components in the device.



PLEASE NOTE! Maintenance and repair work may only be carried out by sufficiently qualified specialist personnel. If in doubt, consult a specialist workshop.



PLEASE NOTE! Improperly performed maintenance work may affect warranty claims.



PLEASE NOTE! For conversion or retrofit sets provided by the manufacturer, it is essential to observe the installation instructions included.

REPLACING DEVICE BATTERIES



BEFORE replacing the batteries, be sure to read carefully the instructions on **DEVICES WITH BATTERY REPLACEMENT PROVIDED BY THE USER** in the safety instructions of this manual!

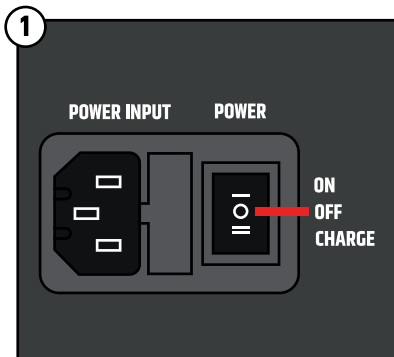

Before replacing the batteries, make sure that the unit is disconnected from the mains and switched off (middle power switch position "OFF" with circle symbol).

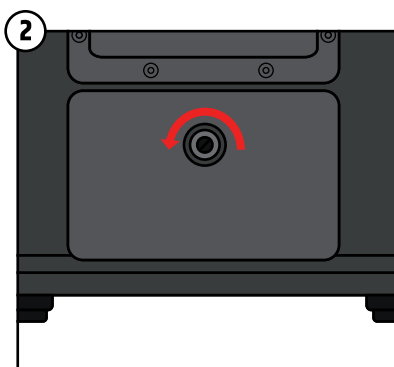

Turn the locking screw of the battery compartment cover counterclockwise to open the battery compartment.

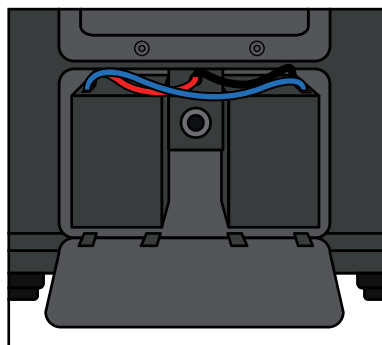

Remove the battery compartment cover from the battery compartment.

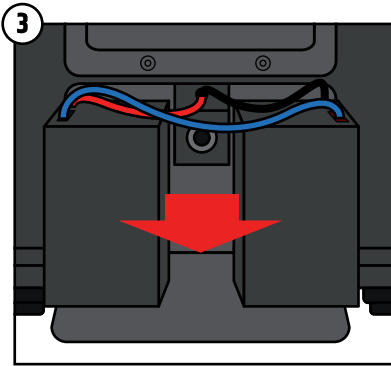

Carefully remove the two batteries from the battery compartment.

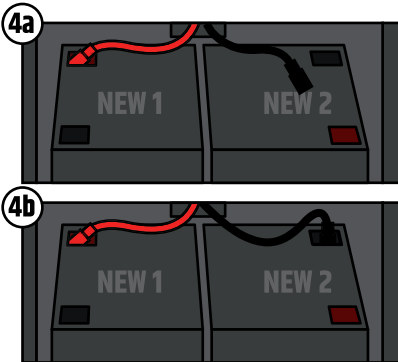

Connect the red appliance cable to the red contact of the first replacement battery. Connect the black appliance cable to the black contact of the second replacement battery.

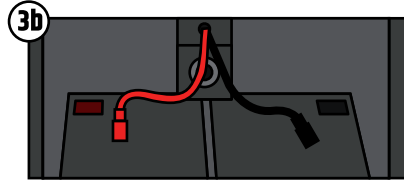
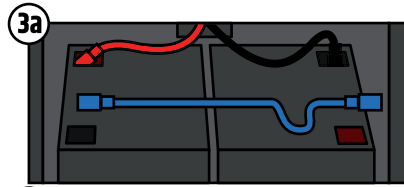

Carefully disconnect the blue cable connecting both batteries from the contacts. Then carefully disconnect the unit cables (red and black) from the contacts of the batteries.

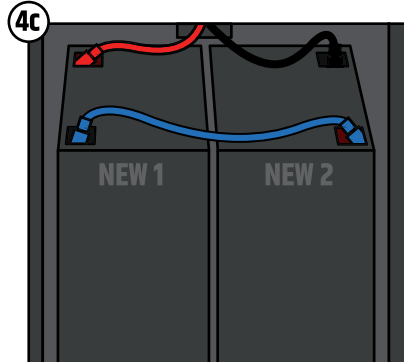

Connect the unused contacts (1 x red and 1 x black) of the two batteries with the blue cable. Make sure that all cables are properly attached to the contacts.

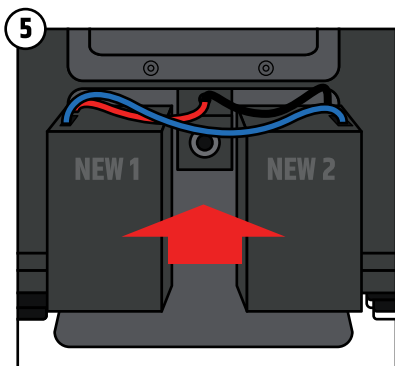

Carefully reinsert both batteries into the battery compartment. Make sure that the cables do not come loose from the contacts. The contacts of the batteries each face inwards. The blue cable should be facing you.

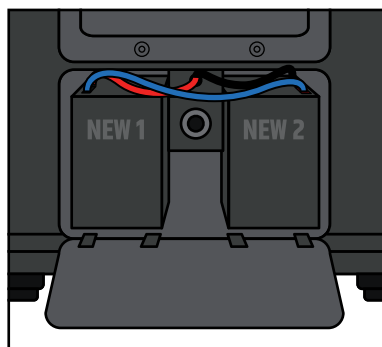

Place the cover with the teeth facing downwards into the corresponding recesses in the battery compartment. Make sure that no cable is pinched.

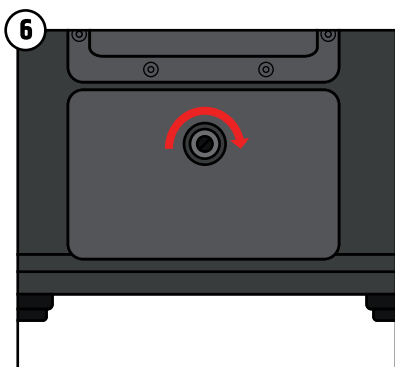

Press the cover against the battery compartment and turn the locking screw clockwise to close the battery compartment again. Make sure that the battery compartment is firmly closed before using the unit again.

OPTIONAL ACCESSORIES

Padded protective cover for ANNY® 10

Item number LDANNY10PC

Receiver Module for ANNY®

Item number LDANNYR

Handheld Microphone for ANNY®

Item number LDANNYMD

Bodypack Transmitter for ANNY®

Item number LDANNYBP



PLEASE NOTE!

To complete the item number for receiver module, handheld and bodypack transmitters, the suffix corresponding to the desired frequency range must be added when ordering an item.

The suffix B8 corresponds to the frequency range 823 – 832 MHz + 863 – 865 MHz.

The suffix B6 corresponds to the frequency range 655 – 679 MHz.

The suffix B5 corresponds to the frequency range 584 – 608 MHz.

The suffix B51 corresponds to the frequency range 514 – 542 MHz (only for the US market)

The suffix B47 corresponds to the frequency range 470 – 490 MHz (only for the US market).

Example: The receiver module with the frequency range 823 – 832 + 863 – 865 MHz has the article number LDANNYRB8.

TECHNICAL DATA

Item number	LDANNY10
General	
Product type	Battery-powered PA speaker
Type	Active
Color	Black
System output (RMS)	80 W
System output (Peak)	160 W
Max. SPL Average (Sine burst)	111 dB
Max. SPL Peak (Sine burst)	118 dB
Frequency response (-10 dB)	45 Hz – 20 kHz
Crossover frequency	1800 Hz
Dispersion (H x V)	120° x 60°
Width	361 mm
Depth	300 mm
Height	566 mm
Features	TWS, 6-channel mixer with system presets, 3-band EQ, effects (reverb & delay), priority/ducking mode, USB-C port für mobile device charging
Weight	18.22 kg (15.35 kg without batteries)
Low/mid woofer	
Low/mid woofer dimensions	10"
Woofer dimensions (mm)	254 mm
Woofer magnet	Ferrite
Woofer brand	Custom made
Woofer voice coil	2"
Woofer voice coil (mm)	51 mm

Item number	LDANNY10
Cabinet construction	Bass reflex
Cabinet material	Polypropylene
HF	
Horn	Constant directivity
Tweeter dimensions	1"
Tweeter dimensions (mm)	25 mm
Tweeter magnet	Ferrite
Tweeter brand	Custom made
Tweeter voice coil	1"
Tweeter voice coil (mm)	25 mm
Amplifier module (integrated)	
Amplifier	Class D
Protection circuits	Short circuit, over temperature
Ambient temperature (in operation)	0 – 40°C
Relative humidity	0 – 80% non-condensing
Fuse	T2AL 250V
Controls	Main Volume/Menu Navigation, Input 1 Volume, Input 1 Mic/Line Switch, Input 2 Volume, Input 2 Mic/Line Switch, Input 3+4 Volume, Input 5+6 (Bluetooth) Volume, Effect, Power
Indicators	Battery status, multifunctional LC display
Power In	IEC
Operating voltage	100 – 240 V 50/60 Hz
Power consumption	150 W
Physical inputs	5
Physical input connectors	2 x 6.3 mm/XLR combo, 2 x RCA, 3.5 mm jack
Mix output	1
Mix output connector	XLR male
Bluetooth Standard	5.0
Bluetooth Audio Decoder	SBC/AAC
Battery	
Rechargeable batteries	12 V / 5 Ah
Battery technology	Lead Acid
Battery type	6FM5
Indicator battery	4-segment LED
Battery operation time music (MUSIC preset, full volume)	5 h

Item number	LDANNY10
Battery operation time music (ECO preset, mid-volume)	25 h
Charging time (80%, no signal)	3.5 h
Charging time (full recharge, no signal)	7 h

Wireless Receiver

Product type	Wireless Microphone System Accessories
Type	Wireless Receiver
Transmission frequency range	470 – 490 MHz (USA version) 512 – 542 MHz (USA version) 584 – 608 MHz 655 – 679 MHz 823 – 832 MHz + 863 – 865 MHz
Modulation Type	FM
Channels	12
Frequency Response	50 – 17000 Hz
Controls	SYNC, Mute Level (Squelch), Power / Volume, Value Down, Value Up
Indicators	AF (LED), LED Display, RF (LED)
Connections	BNC for receiver antenna, Audio out

Dynamic Handheld Microphone

Product type	Wireless Microphone System Accessories
Type	Microphone
Transmission frequency range	470 – 490 MHz (USA version) 512 – 542 MHz (USA version) 584 – 608 MHz 655 – 679 MHz 823 – 832 MHz + 863 – 865 MHz
Channels	12
Microphone type	Dynamic
Directivity	Cardioid
Frequency response	60 Hz – 20 kHz
Signal-to-noise ratio	104 dB
Rated HF output power	10 mW
Controls	Power on/off
Indicators	Power/battery status low (LED)
Operating voltage	2 x AA battery
Operating Time	8 h
Length	250.4 mm

Item number	LDANNY10
Diameter	32.5 mm (body)
Weight	0.25 kg
Other features	Incl. batteries, IR frequency synchronisation

Bodypack Transmitter

Product type	Wireless Microphone System Accessories
Type	Bodypack
Transmission frequency range	470 – 490 MHz (USA version) 512 – 542 MHz (USA version) 584 – 608 MHz 655 – 679 MHz 823 – 832 MHz + 863 – 865 MHz
Channels	12
Inputs	Mini-XLR (3-pin)
Frequency response	45 Hz – 20 kHz
Signal-to-noise ratio	100 dB
Rated HF output power	10 mW
Controls	Power on/standby/off, Gain switch
Indicators	Power/battery status low (LED)
Operating voltage	2 x AA battery
Operating time	8 h
Width	64 mm
Height	100 mm (without antenna)
Depth	21 mm (without belt clip)
Weight	0.15 kg
Other features	IR frequency synchronisation, switchable gain, standby-mode, incl. batteries

Headset

Product type	Wireless Microphone System Accessories
Type	Headset
Frequency response	50 Hz – 12 kHz
Directivity	Cardioid
Nominal impedance	680 Ohm(s)
Phantom power requirements	5 V
Microphone input	Mini-XLR (3-pin, female)
Accessories (included)	Foam windscreen
Weight	0.049 kg

DISPOSAL



Packaging:

1. Packaging can be fed into the reusable material cycle using the usual disposal methods.
2. Please separate the packaging in accordance with the disposal laws and recycling regulations in your country.



Device:

1. This appliance is subject to the European Directive on Waste Electrical and Electronic Equipment as amended. WEEE Directive Waste Electrical and Electronic Equipment. Old appliances and batteries do not belong in household waste. The old appliance or batteries must be disposed of via an approved waste disposal company or a municipal waste disposal facility. Please observe applicable regulations in your country!
2. Observe all disposal laws applicable in your country.
3. As a private customer, you can obtain information on environmentally friendly disposal options from the dealer from whom the product was purchased or from the relevant regional authorities.

MANUFACTURER'S DECLARATIONS

MANUFACTURER'S WARRANTY & LIMITATIONS OF LIABILITY

Adam Hall GmbH, Adam-Hall-Str. 1, D-61267 Neu Anspach / E-mail Info@adamhall.com / +49 (0)6081 / 9419-0.

Our current warranty conditions and limitation of liability can be found at:

https://cdn-shop.adamhall.com/media/pdf/MANUFACTURERS-DECLARATIONS_LD_SYSTEMS.pdf.

Contact your distribution partner for service.

UKCA-CONFORMITY

Hereby, Adam Hall Ltd. declares that this product meets the following guidelines (where applicable):

Electrical Equipment (Safety) Regulations 2016

Electromagnetic Compatibility Regulations 2016 (SI 2016/1091)

The Restriction of the Use of Certain Hazardous Substances in Electrical and Electronic Equipment Regulation 2012 (SI 2012/3032)

Radio Equipment Regulations 2017 (SI 2016/2015)

UKCA-DECLARATION OF CONFORMITY

Products that are subject to Electrical Equipment(Safety)Regulation 2016, EMC Regulation 2016 or RoHS Regulation can be requested at info@adamhall.com.

Products that are subject to the Radio Equipments Regulations 2017 (SI2017/1206) can be downloaded from www.adamhall.com/compliance/

FCC STATEMENT

This equipment has been tested and found to comply with the limits for a Class B digital device, pursuant to part 15 of the FCC Rules. These limits are designed to provide reasonable protection against harmful interference in a residential installation. This equipment generates, uses and can radiate radio frequency energy and, if not installed and used in accordance with the instructions, may cause harmful interference to radio communications. However, there is no guarantee that interference will not occur in a particular installation. If this equipment does cause harmful interference to radio or television reception, which can be determined by turning the equipment off and on, the user is encouraged to try to correct the interference by one or more of the following measures:

- Reorient or relocate the receiving antenna.
- Increase the separation between the equipment and receiver.
- Connect the equipment into an outlet on a circuit different from that to which the receiver is connected.
- Consult the dealer or an experienced radio/TV technician for help.

Caution: Any changes or modifications to this device not explicitly approved by manufacturer could void your authority to operate this equipment.

This device complies with part 15 of the FCC Rules. Operation is subject to the following two conditions: (1) This device may not cause harmful interference, and (2) this device must accept any interference received, including interference that may cause undesired operation.

RF EXPOSURE INFORMATION

This equipment complies with FCC radiation exposure limits set forth for an uncontrolled environment. This equipment should be installed and operated with minimum distance 20cm between the radiator and your body.

CE CONFORMITY

Adam Hall GmbH hereby confirm that this product meets the following guidelines (where applicable): R&TTE (1999/5/EC) or RED (2014/53/EU) as of June 2017.

Low Voltage Directive (2014/35/EU)

EMC Directive (2014/30/EU)

RoHS (2011/65/EU)

The complete Declaration of Conformity can be found at www.adamhall.com.

Furthermore, you can also request it at info@adamhall.com.

CE DECLARATION OF CONFORMITY

Declarations of conformity for products subject to the LVD, EMC, RoHS Directive can be requested from info@adamhall.com.

Declarations of conformity for products subject to RED Directive can be downloaded from www.adamhall.com/compliance/.

Subject to misprints and errors, as well as technical or other modifications!

This page has been intentionally left blank

