



DNH

DSP-15EExmN(T)

Commercial Audio Solutions Ltd

The Old Barn, Whitecroft Farm

Strines, Derbyshire. SK22 3AH.

Tel: 01663 767888

Email: sales@commercialaudiosolutions.com

Web: www.commercialaudiosolutions.com

ISO 9001 CERTIFIED

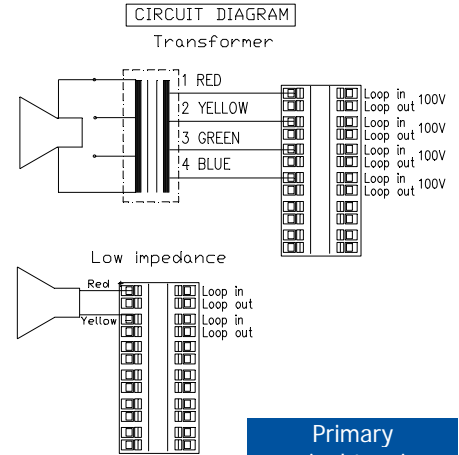
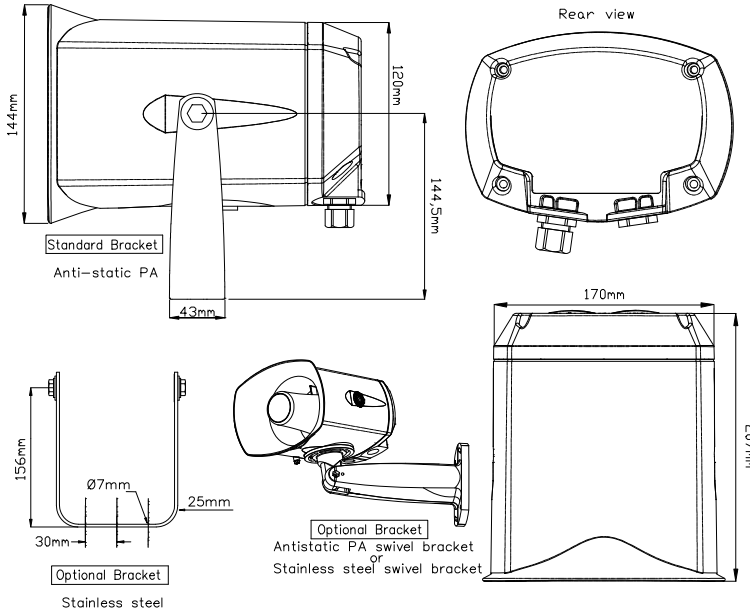

Standard model delivered with two M20 Ex approved plastic blinding plugs.

Ex marking:

- II 2G Ex db eb mb IIB+Hz / IIC T4 Gb (Zone 1)
- II 2D Ex tb IIIC T105°C Db (Zone 21)

Certified:

IECEX, ATEX, Inmetro, EAC, CCC, UL/CSA, BV, +
Contact Sales for requested certificates and marking for product.

Sound pressure levels at 1W/1m RAV67 SPL vs Freq

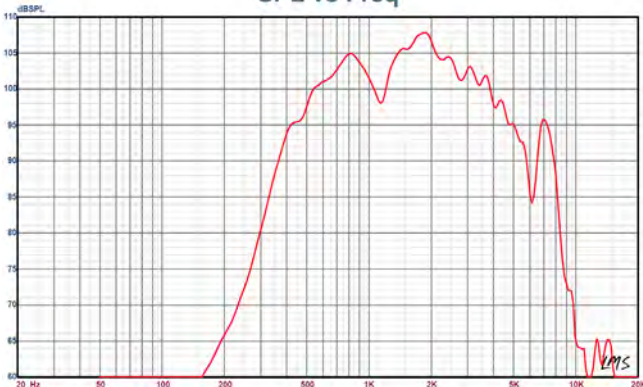

Specifications

	IIB	IIC
Material / Color	Anti-static PA / Black	
Mounting	Bracket	
Termination	e-chamber, push terminals	
Weight w/transformer	2,2 kg	
IP-rating	66 / 67	
Max. / min. amb. temp	60°C / -50°C	
Rated / max. power	25 W / 30 W	
SPL 1W/1m	106 dB	104 dB
SPL rated power	118 dB	115 dB
Effective freq. range	380 – 8000 Hz	450-7000
Dispersion (-6dB) 1kHz / 4kHz	120° / 37°	105° / 35°
Directivity factor, Q 1kHz/4kHz	4,5 / 9,6	
Options	Impedances, labels, transformers, maintenance free (MF), cables, bracket	

Installation, Operation and Maintenance Procedures

- Remove lid by four screws, lead cable through the cable gland and connect to terminal with required tapping.
- Every time the back lid is removed, check that the gasket is fitted correctly to the lid before you refit the back lid. Do not use any lubricants on the gasket.
- Screw lid back into place by four screws with a torque of 1,8Nm to assure the IP rating.
- To change the position of the loudspeaker, please adjust the standard U-bracket (by loosening / tightening the screws) as required.
- Use only IECEX/ATEX certified "Ex eb" cable glands and blinding plugs reflecting the same IP rating and temperature range as the loudspeaker.
- Standard model delivered with two M20 Ex approved plastic blinding plugs.
- DSP-15EExmN(T) can be supplied with three different bracket systems, according to customer requirements.
- For optimum performance, always use the correct voltage / power and operate within the frequency limits as stated.
- Do not open loudspeaker when energized.
- This loudspeaker is supplied with two years warranty against defective workmanship.

DNH reserves the right to alter specifications without notice.

